

# 1.85mm series

The 1.85mm was designed to go beyond the SMA interface constraints, and as a result is NOT SMA compatible. Instead, maximum performance to the highest possible frequency that the geometry would allow, along with repeatable measurements after hundreds or even thousands of interconnects, were the design goals.

The connector outer conductor ID is 1.85 mm, and OD is 4.7 mm, allowing compatibility, so that the 1.85mm connector mates with the 2.4mm connector and has the same ruggedness. It's a 50 Ohms connector with performance up to 67 GHz.

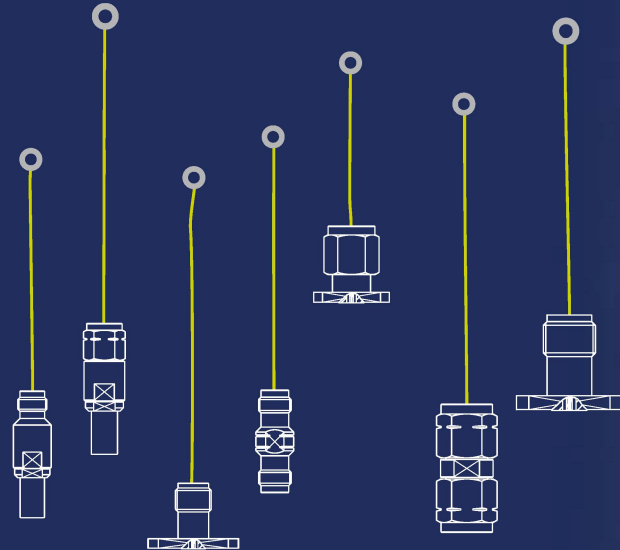

## INTERFACE MATING DIMENSIONS

### PLUG /

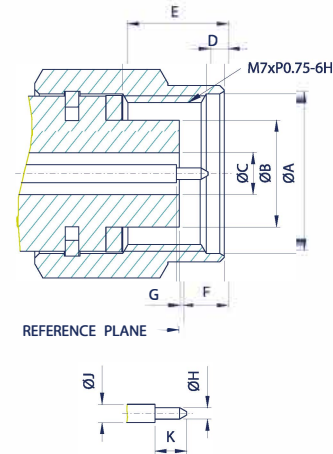

### JACK /

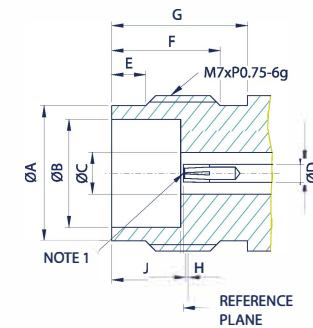

Letter	PLUG	
	Millimeters	
	Minimum	Maximum
A	7.01	7.11
B	4.72	4.75
C	1.84	1.86
D	0.51	0.76
E	4.37	4.62
F	1.86	2.45
G	0	0.08
H	0.5	0.52
J	0.79	0.81
K	1.34	1.44

Letter	JACK	
	Millimeters	
	Minimum	Maximum
A	5.79	5.89
B	4.77	4.79
C	1.84	1.86
D	0.79	0.81
E	1.40	1.65
F	4.81	5.06
G	5.99	-
H	0	0.08
J	3	3.1

**NOTE 1:** I.D. TO MEET VSWR AND CONTACT RESISTANCE WHEN MATED WITH 0.5 / 0.52 MM DIA. PIN.

## SPECIFICATIONS

### Electrical /

Impedance	50 Ohm	
Frequency Range	0 - 67 GHz	
Insertion Loss	$0.05 \times \sqrt{F(\text{GHz})}$ dB Max.	
VSWR	1.3 Max.	
Contact Resistance	Center Contact	4 Milliohms Max.
	Outer Contact	2.5 Milliohms Max.

### Material /

Parts Name	Material	Finish
Body, Metal Parts	Stainless Steel per QQ-S-764	Passivated
Center Contacts	Male: Beryllium copper per QQ-C-530	Gold 50 micro-inches
	Female: Beryllium copper per QQ-C-530	Gold 50 micro-inches
Insulators	Rexolite	None

**NOTE:** Other Material / Finish is Available on Request.

### Mechanical & Environmental /

Coupling Torque Recommended	0.8 Nm...1.1 Nm
Coupling Proof Torque	1.65 Nm
Durability (Mating)	500 cycles Min.
Temperature Range	-40°C to 85°C

# 1.85mm series

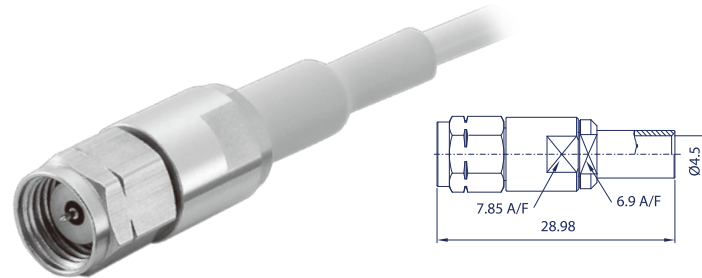

DIRECT SOLDER PLUG

Model No.	Cable Group	Impedance
FL33P2-NS5	RG-405 (.085", .086"), SS-405 IW 1251	50

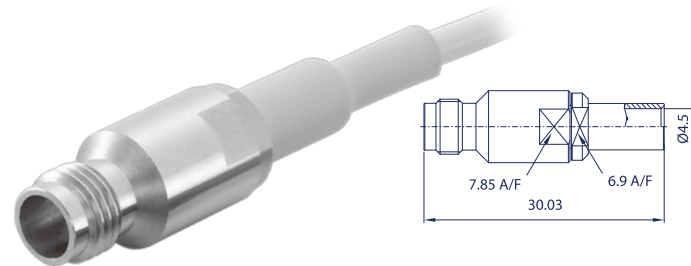

DIRECT SOLDER JACK

Model No.	Cable Group	Impedance
FL33J2-NS5	RG-405 (.085", .086"), SS-405 IW 1251	50

18

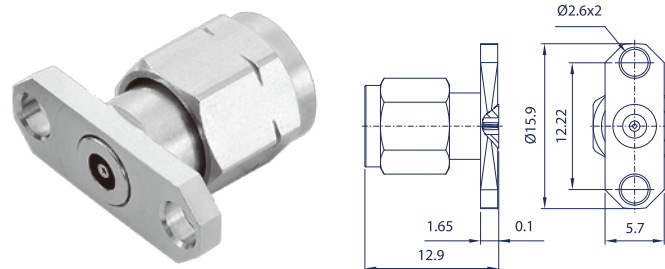

PANEL RECEIPT PLUG-ACCEPTS PIN

Model No.	Cable Group	Impedance
FL33P9-ES505	N/A	50

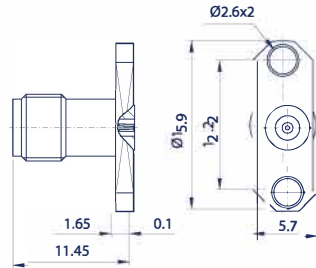

PANEL RECEIPT JACK-ACCEPTS PIN

Model No.	Cable Group	Impedance
FL33J9-ES505	N/A	50

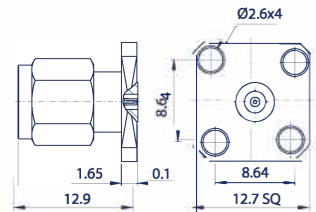

PANEL RECEIPT PLUG-ACCEPTS PIN

Model No.	Cable Group	Impedance
FL33P9-FS505	N/A	50

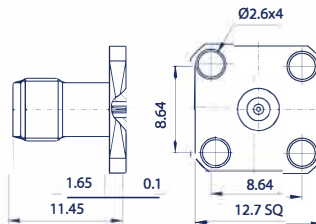
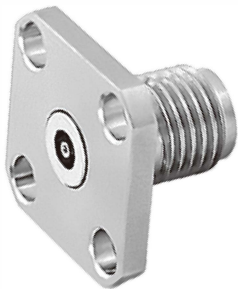

PANEL RECEIPT JACK-ACCEPTS PIN

Model No.	Cable Group	Impedance
FL33J9-FS505	N/A	50

# 1.85mm series

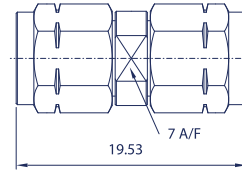

PLUG TO PLUG ADAPTOR

Model No.	Cable Group	Impedance
FL33B8-NS5	N/A	50

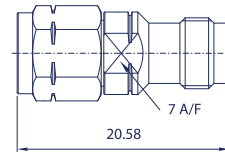

PLUG TO JACK ADAPTOR

Model No.	Cable Group	Impedance
FL33E8-NS5	N/A	50

20

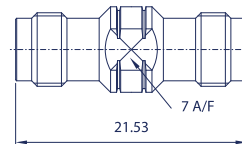

JACK TO JACK ADAPTOR

Model No.	Cable Group	Impedance
FL33G8-NS5	N/A	50