

2018



SIRIO[®]

antenne

- TETRA
- LoRa
- GSM DUAL
- UMTS
- 3G / 4G
- LTE
- W-LAN 2.4
- W-LAN 5.4

 WIRELESS
DIVISION

High-TECHNOLOGY ANTENNAS
DESIGNED AND MANUFACTURED IN ITALY





Sirio Antenne was established in 1972 in Volta Mantovana, a small town a few kilometres from Lake Garda, characterized by its ancient medieval castle. The company's location is logistically strategic for the development of its business and also easily reachable from the nearby Verona airport, which is only 35km away.

Here Giuseppe Grazioli began his activity and founded Sirio Antenne. He firmly believed in the future of WIRELESS' communication, at that time used only by the military, and decided to dedicate himself to the development of wider applications for civil use, contributing to a NEW form of communication now in common everyday use.



RF & Microwave lab.

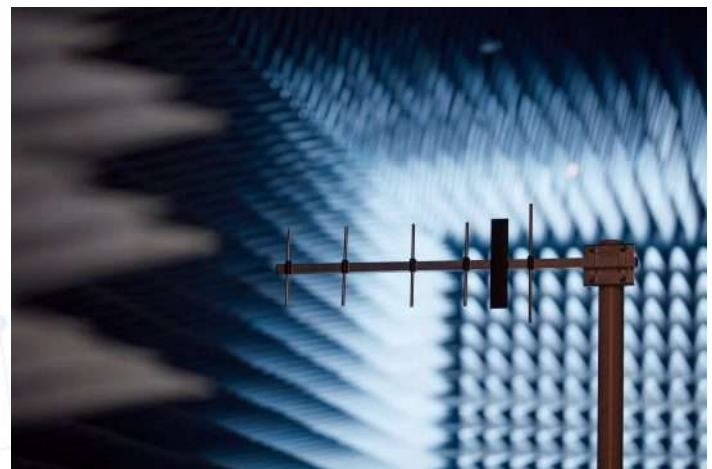

Microwave anechoic chamber.



Main office

QUALITY SYSTEM
SIRIO antenne is a qualified ISO9001:2015 company since February 2004
 Certification issued by international company DNV-GL



RESEARCH & DEVELOPMENT DEPARTMENT



RF & Microwave lab.

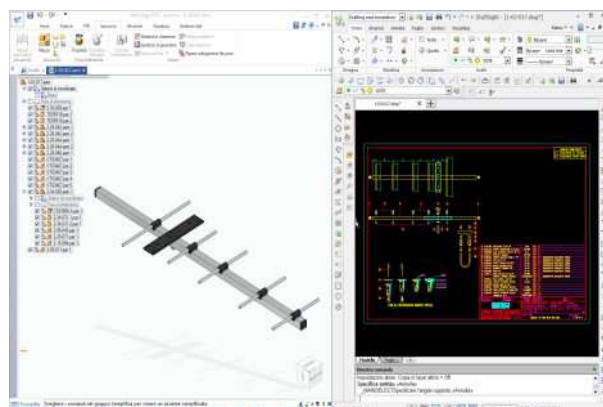

CAD 2D & 3D for mechanical design

PRODUCTION DEPT



Mobile antennas production department



Ultrasonic welding machine



CNC winding machine



Coaxial cable cutting machines



Final test with network analyzer

MACHINES SHOP

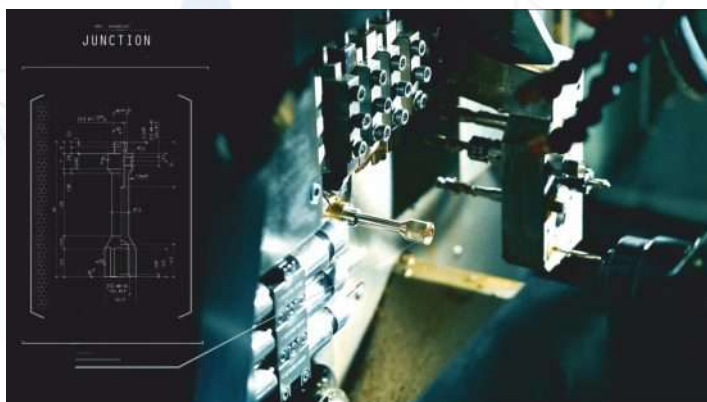

Sliding headstock CNC-lathe machines view



CNC machining centre view



REFERENCE TABLE



Here below you'll find table **A** that will help you to easily find out the most suitable product for your purpose.

1) CHOOSE THE TYPE OF INSTALLATION. **BASE** station or vehicular **MOBILE** antennas.

2) CHOOSE THE FREQUENCY BAND. At the top of the table you can choose your preferred frequency band or the nearest one.

3) CHOOSE THE PRODUCT. Follow the vertical line of the chosen frequency band till you find the **coloured squares** that show the frequency bands covered. The name of the product and its corresponding data page is on the left side. You can easily find the page of your selected product.

ADDITIONAL INFORMATION

All products have a **FIXED** band and no tuning is required. The corresponding frequency range is covered within a SWR limit indicated in the product's electrical data.



TABLEAUX DE REFERENCES



Vous trouverez ci-dessous un tableau qui va faciliter la recherche d'un produit dans le catalogue. La procédure de recherche est la suivante:

1) CHOISIR LE TYPE D'INSTALLATION. Les antennes de stations **FIXES** sont dans la partie supérieure de tableau. Les antennes **MOBILES** sont dans la partie basse du tableau.

2) CHOISIR LA FREQUENCE. En haut du tableau, choisissez la bande de fréquences désirée. Si elle n'est pas mentionnée, veuillez choisir celle qui s'en rapproche le plus.

3) CHOISIR LE PRODUIT. Suivez la ligne verticale de la gamme de fréquences choisie jusqu'à ce que vous trouviez les **emplacements colorés** qui désignent les bandes de fréquences couvertes. Le nom du produit et la page correspondante dans le catalogue sont sur le côté gauche. Vous trouverez ainsi plus facilement la page du produit sélectionné.

INFORMATIONS COMPLEMENTAIRES

Toute antenne a une bande de fréquences **FIXE** et qu'on ne peut pas la modifier. Aucun réglage n'est nécessaire et la limite de SWR de la bande de fréquences couverte est indiquée dans les spécifications du produit.



TABELLA DI RICERCA



Di seguito è riportata la tabella **A** con lo scopo di facilitare la ricerca dei prodotti. La procedura di ricerca consiste in:

1) SCELTA TIPO DI INSTALLAZIONE. La parte superiore della tabella riporta i modelli per **stazione BASE**, le antenne **MOBILE** per installazione su veicoli sono riportati nella parte inferiore.

2) SCELTA BANDA DI LAVORO. Individuare nella **riga superiore** delle tabella la banda di lavoro desiderata. Se non fosse riportata individuare quella che possiede banda di lavoro più simile.

3) SCELTA PRODOTTO. Scorrere la riga verticale corrispondente alla banda di lavoro voluta fino ad incrociare i **rettangoli colorati** che indicano le bande di frequenze coperte. Pagina e modello sono riportati sulla stessa riga alla sinistra dei rettangoli così individuati. Consultare quindi la pagina del prodotto per conoscere tutte le particolarità.

INFORMAZIONI AGGIUNTIVE

Tutti i prodotti hanno una banda **FISSA** non modificabile. Non occorre tarare nulla e tutta la banda dichiarata è coperta entro un limite di SWR specificato.



TABLA DE REFERENCIA



Encontraremos la tabla **A** para facilitar la búsqueda de los productos. El procedimiento consiste en:

1) SELECCION EL TIPO DE INSTALACIÓN. Las antenas para **BASE** están situadas en la parte superior, las antenas **MOVILES** los encontraremos en la parte inferior de la tabla.

2) ELECCION DE LA FRECUENCIA. Seleccione en la línea superior de la tabla, el rango de frecuencia deseado. Si la frecuencia de trabajo no aparece, seleccionaremos la más próxima.

3) ELECCION DEL PRODUCTO. Siga la línea vertical correspondiente al rango de frecuencia deseado hasta que encontraremos los **cuadrados coloreados** que muestran el rango de frecuencia para cada modelo. El nombre del producto y los datos correspondientes a la página están en el lado izquierdo. De esta manera, localizaremos el producto y la página con facilidad.

INFORMACION ADICIONAL

Las antenas no son modificables en su rango de frecuencia. No precisan ningún ajuste y cubren toda la banda especificada con el nivel de ROE.

The frequencies table for the most common systems / Tabella delle bande di frequenze dei sistemi più utilizzati

Band	Frequency	System / Name	Band	Frequency	System / Name
VHF	87.5 - 108 MHz	FM radio	UHF	1575.42 MHz	GPS
UHF	380 - 440 MHz	TETRA	UHF	1.71 - 1.88 GHz	PCN / GSM 1800, DCS 1800
UHF	698 - 790 MHz	LTE 700: bands 12, 13, 17, 28, 44, 68, 71....	UHF	1.85 - 1.99 GHz	PCS, DCS 1900 / GSM 1900
UHF	790 - 824 MHz	LTE 800: bands 20, 27.....	UHF	1.92 - 2.17 GHz	UMTS
UHF	824 - 894 MHz	AMPS, LTE bands 5, 6	UHF	2.4 - 2.485 GHz	W-LAN IEEE 802.11b
UHF	810 - 958 MHz	DoCoMo	UHF	2.3 - 2.7 GHz	Wi-MAX
UHF	868 - 870 MHz	ISM	SHF	3.3 - 3.8 GHz	Wi-MAX
UHF	902 - 928 MHz	ISM	SHF	5.15 - 5.35 GHz	W-LAN IEEE 802.11a (UNI1, UNI2)
UHF	880 - 960 MHz	GSM 900, LTE band 8	SHF	5.47 - 5.875 GHz	W-LAN IEEE 802.11a (UNI3)
UHF	890 - 960 MHz	NMT 900, Natel C	SHF	5.855-5.925 GHz	V2X, W-LAN IEEE 802.11p

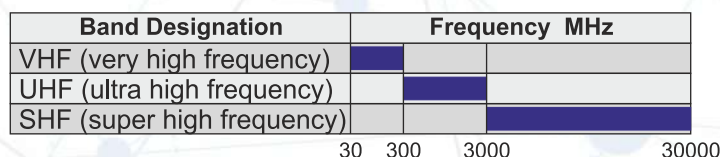

Table A

Installation																											
Type	Page	Model	TETRA-350	TETRA	CDMA	ISM/SIGFOX/LoRa	70cm HAM	LTE-450	ISM/SIGFOX/LoRa	ISM/SIGFOX/LoRa	GSM-R	GSM-900	GSM-1800	DECT	UMTS	2G-GSM/GPRS/EDGE	3G-UMTS	4G-LTE	WiFi-2.4 GHz, ZIG BEE	WiMAX	WiFi-5 GHz	V2X					
			(350-370 MHz)	(380-470 MHz)	(410-470 MHz)	(433 MHz)	(430-450 MHz)	(451-468 MHz)	(868-870 MHz)	(915 MHz)	(876-924 MHz)	(880-960 MHz)	(1.71-1.88 GHz)	(1.88-1.99 GHz)	(1.92-2.17 GHz)	(880-960 & 1710-1880 MHz)	(880-960 & 1710-2170 MHz)	(790-960 & 1710-2700 MHz)	(2.4-2.485 GHz)	(2.3-2.7 & 2.3-3.8 GHz)	(5.15-5.875 GHz)	(5.85-5.925 GHz)					
BASE INSTALLATION	OMNIDIRECTIONAL	5, 6	SPO UHF series																								
		7	SO 4G																								
		8	HGO 433-868																								
		8	HGO 4G LTE																								
		9	GP 868 C																								
		9	GP 900 C																								
		9	GP 901 C																								
		10	CX 840																								
		10	CX 868																								
		10	CX 900																								
		10	OMNI 900 6 dBi																								
		11	SO-918-2																								
		11	SO-918-2 M1																								
		12	SO 868-915																								
		12	SCO-868-4																								
		12	SCO-868-6																								
		13, 14	SCO-1.93-6																								
		13, 14	SCO-2-6																								
		13, 14	SCO-2.4-6																								
		13, 14	SCO-2.4-9																								
		13, 14	SCO-3.3-7																								
		13, 14	SCO-3.3-10																								
		13, 14	SCO-5.47-10																								
		13, 14	SCO-2451																								
		15	SCM-918-2																								
		16	PA-2.4-2 TNC																								
		16	PA-2.4-2 SMA																								
		MOBILE INSTAL.	HOLE	17, 18	WY UHF series																						
				19, 20	SMP 4G LTE																						
				19, 20	SMP 4G LTE MIMO																						
19, 20	SMP 24-33																										
21	SLP-1.7÷2.5-11																										
22	SPH-1.5÷6-17																										
23	SY 906																										
23	SY 910																										
24	SDC-2.4-15																										
25	LPA																										
MOBILE INSTAL.	MAG	26	CELLFLEX																								
		27	SKA 900 1/4																								
		27	SKA 901 C																								
		27	SKA 900 1/4 MAG																								
		27	SKA 901 C MAG																								
		27	MICROMAG 918																								
		28	INGLASS Multiband																								
		28	INGLASS Lte & Wlan																								
		29	accessories																								
		30	connectors, adaptors																								

SPO series

Sirio Professional Omnidirectional 350-470 MHz

WIDE-BAND

*Fiberglass
dipole and colinear*

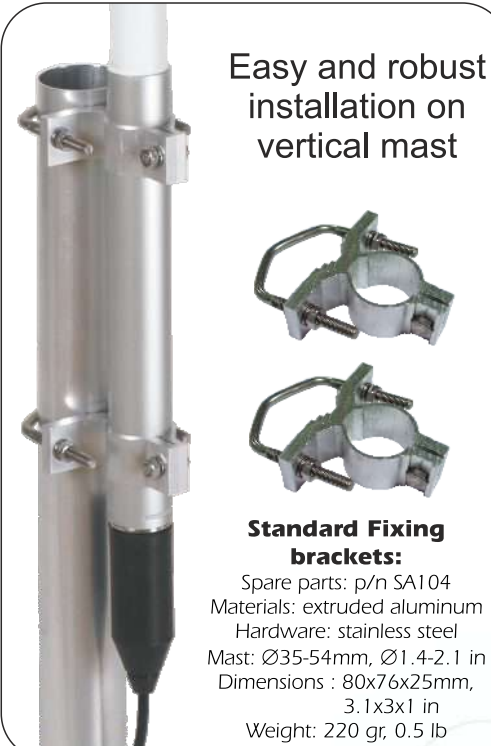

Easy and robust installation on vertical mast

Standard Fixing brackets:
 Spare parts: p/n SA104
 Materials: extruded aluminum
 Hardware: stainless steel
 Mast: Ø35-54mm, Ø1.4-2.1 in
 Dimensions : 80x76x25mm, 3.1x3x1 in
 Weight: 220 gr, 0.5 lb



Horizontal mast

Optional bracket: (antenna height 2m / 6.5ft MAX)
 Spare parts: p/n SA197
 Materials: extruded aluminum
 Hardware: stainless steel
 Mast: Ø35-52mm, Ø1.4-2.0 in
 Dimensions : 80x76x65mm, 3.1x3x2.3 in
 Weight: 460 gr, 1 lb



SPO 380-2
Dipole



SPO 350-5
SPO 380-5
SPO 420-5
Colinear



SPO 380-8
SPO 400-8
SPO 440-8
Colinear

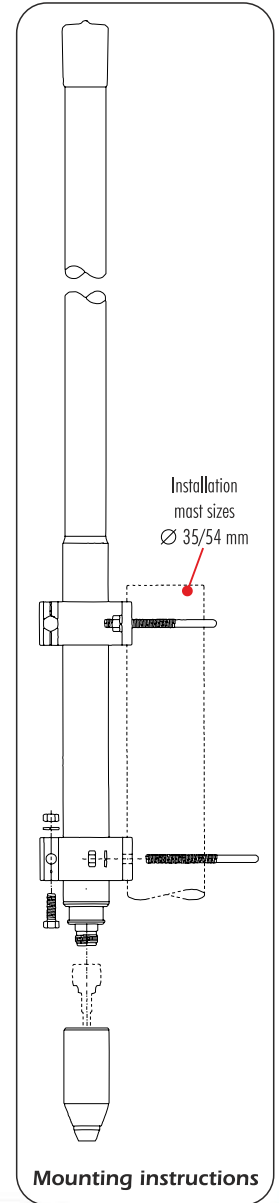

SPO series

Sirio Professional Omnidirectional 350-470 MHz

Features:

- # Fiberglass wide-band omnidirectional base station antenna. No tuning required
- # SPO 380-2: Unity-gain; SPO 350/380/420-5: Medium-gain; SPO 380/400/420/440-8: High-gain
- # Perfect protection against the worst weather conditions; Protection from static discharges DC-Ground
- # Designed to work without Ground Plane; Stainless steel hardware

Electrical Data	SPO 380-2	SPO 350-5	SPO 380-5	SPO 420-5	SPO 380-8	SPO 400-8	SPO 420-8	SPO 440-8
Type	Dipole	Colinear						
Frequency Range @ SWR ≤ 1.5	380-470 MHz	350-400 MHz	380-430 MHz	420-470 MHz	380-406 MHz	400-430 MHz	420-450 MHz	440-470 MHz
Impedance	50 Ω							
Radiation (H-plane)	360° Omnidirectional							
Radiation (E-plane) beamwidth @ -3 dB	78°	40°	40°	40°	14°	14°	14°	14°
Polarization	Linear Vertical							
Gain	0 dBd - 2.15 dBi	3 dBd - 5.15 dBi	3 dBd - 5.15 dBi	3 dBd - 5.15 dBi	6 dBd - 8.15 dBi	6 dBd - 8.15 dBi	6 dBd - 8.15 dBi	6 dBd - 8.15 dBi
Max Power (CW) @ 30° C	75 Watts							
Grounding Protection	All metal parts are DC-grounded, the inner conductor shows a DC short							
Connector	N-female with rubber protection cap							

Mechanical Data

Materials	White cylindrical fiberglass radome Ø 28.6 mm, anodized 6063-T5 aluminium, brass, stainless steel, copper, EPDM rubber							
Wind Load @ 150 km/h	33 N	53 N	53 N	53 N	104 N	104 N	98 N	93 N
Wind Resistance	200Km/h, 124mi/h	180Km/h, 112mi/h	180Km/h, 112mi/h	180Km/h, 112mi/h	150Km/h, 93mi/h	150Km/h, 93mi/h	150Km/h, 93mi/h	150Km/h, 93mi/h
Wind Surface	0.027m ² , 0.29ft ²	0.044m ² , 0.47ft ²	0.044m ² , 0.47ft ²	0.044m ² , 0.47ft ²	0.089m ² , 0.95ft ²	0.089m ² , 0.95ft ²	0.083m ² , 0.88ft ²	0.079m ² , 0.84ft ²
Height (approx.)	780 mm, 2.55 ft	1380 mm, 4.5 ft	1380 mm, 4.5 ft	1380 mm, 4.5 ft	2940 mm, 9.6 ft	2940 mm, 9.6 ft	2740 mm, 9 ft	2590 mm, 6 ft
Weight (approx.)	890 gr, 2 lb	1240 gr, 2.73 lb	1215 gr, 2.7 lb	1200 gr, 2.6 lb	2040 gr, 4.5 lb	2020 gr, 4.5 lb	1935 gr, 4.3 lb	1850 gr, 4.1 lb
Operating temperature	-40° C to +80° C							
Mounting Mast	Side vertical mast with "V" bolt Ø 35 - 54 mm, Ø 1.4 - 2.1 in							
P/N	2115020/380	2115120/350	2115120/380	2115120/420	2115320/380	2115320/400	2115320/420	2115320/440

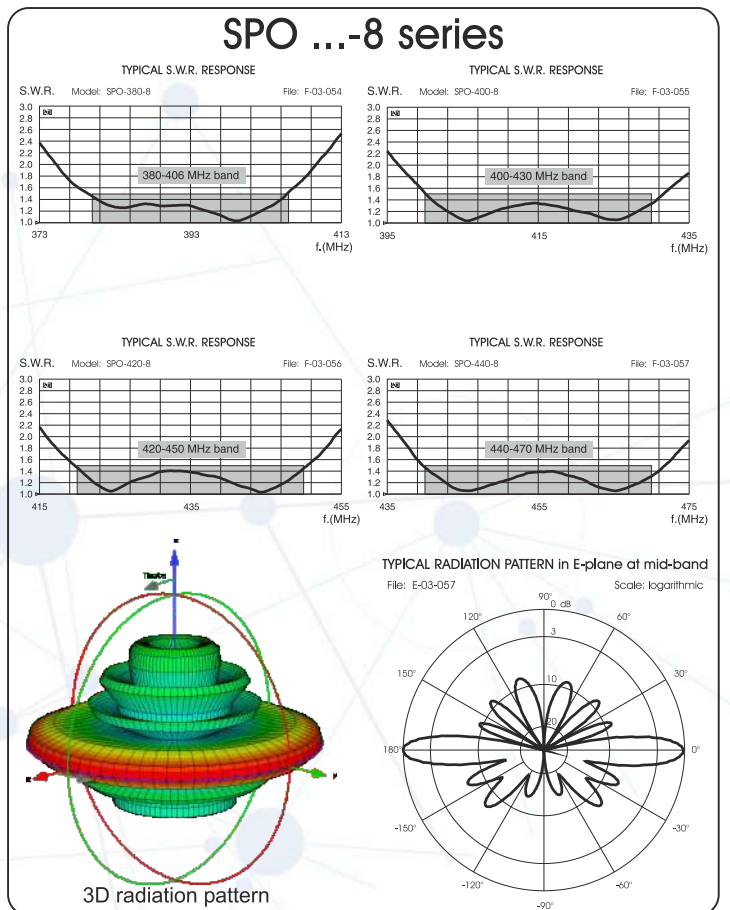
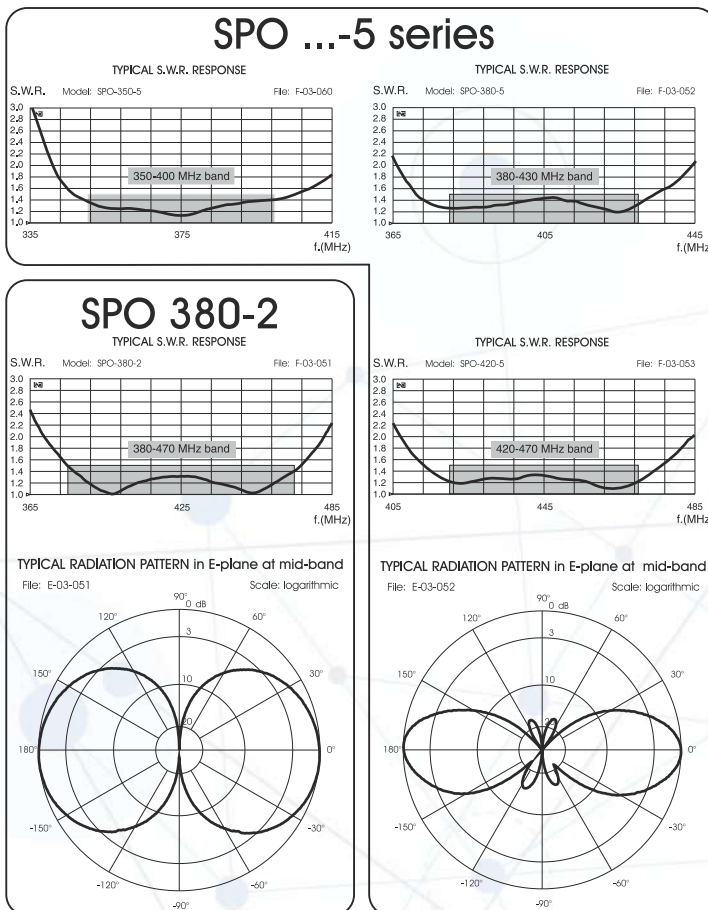

SO 4G LTE

Sirio Omnidirectional 4G LTE bands

Features:

- # Base station antenna, Omnidirectional
- # High quality PCB radiator protected by fiberglass tube
- # For LTE 800, ISM 868 & 915, AMPS, GSM dual, UMTS, WLAN, LTE systems

NEW MODELS

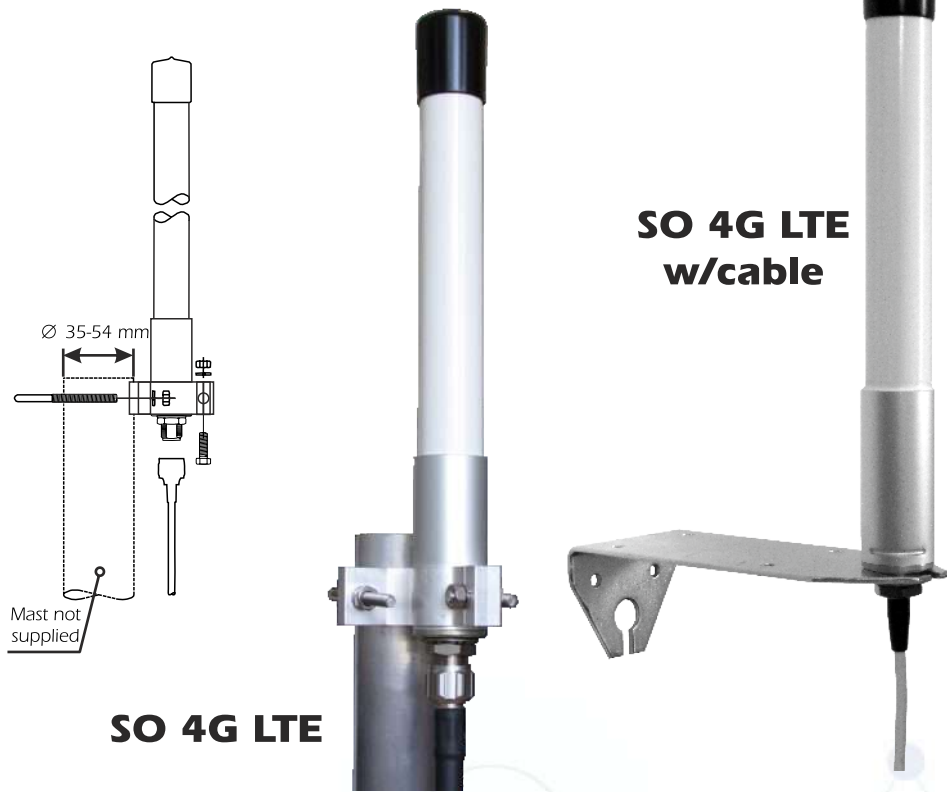

SO 4G LTE w/cable

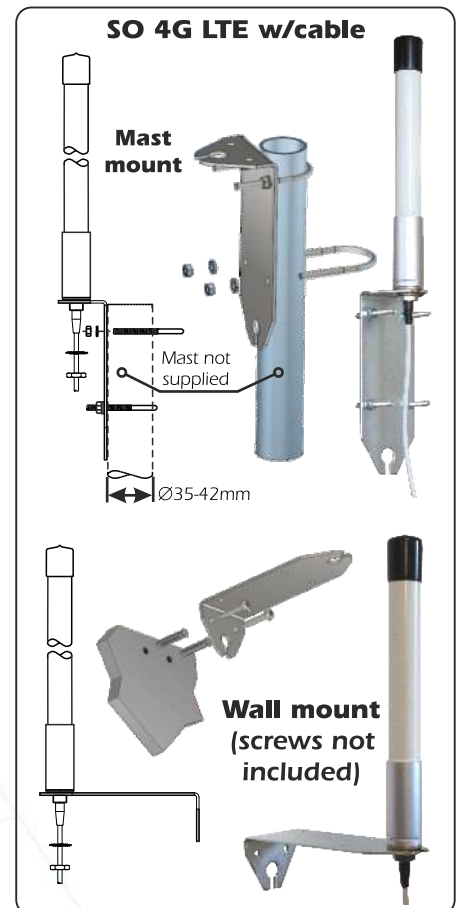

Electrical Data	SO 4G LTE	SO 4G LTE cable version
Type	Colinear Dipole Array	
Frequency Range @ SWR ≤ 2.2	790 - 960 MHz (LTE, ISM, GSM 900) & 1.71 - 2.7 GHz (GSM 1.8, PCN, DECT, UMTS, WLAN, LTE)	
Impedance	50 Ω	
Radiation (H-plane)	360° omnidirectional	
Radiation (E-plane)	Beamwidth @ -3 dB: see diagrams	
Radiation angle deg.	see diagrams	
Polarization	Linear Vertical	
Gain	2 dBi @ 790-960 MHz; 4 dBi @ 1.71-2.7 GHz	
Max Power (CW) @ 30° C	25 Watts	
Cable Type / Length	/	Low Loss cable / 5m, 16.4 ft
Connector	N-female, gold plated central pin	SMA-male, other type on request
Mechanical Data		
Housing & Radome Material	Fiberglass, Anodized aluminium, Chromed Brass	
Bracket & Hardware Material	Aluminium, Stainless steel	Galvanized steel
Wind Load / Resistance	14 N @ 150 Km/h, 93 mi/h / 200 Km/h, 124 mi/h	
Wind Surface	0.011 m ² ; 0.12 ft ²	
Height (approx.)	300 mm, 1 ft	
Weight (without bracket, approx.)	230 gr, 0.5 lb	495 gr, 1.1 lb
Operating Temperature	-30 °C to +70 °C	
Installation type	Mast: Ø 35-54 mm, Ø 1.4-2.1 in with V-bolt	M3 bracket: Mast: Ø35-42mm, Ø1.4-1.65 in with U-bolt Wall: with screws (not included)
P/N	2111520.00	2111520.80

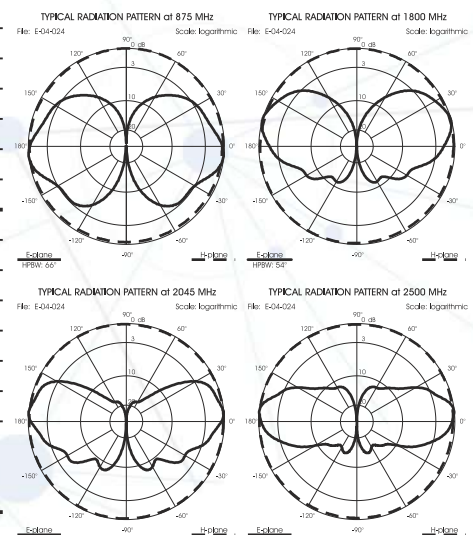

HGO 4G LTE Improved

compact High Gain Omnidirectional

HGO 433-868

Features:

- # Flat Design and very compact base station antenna
- # Omnidirectional, Multi-band, High-gain, no tuning required
- # High quality PCB radiator protected by UV stabilized thermoplastic cover
- # HGO 433-868: For ISM 433 & 868
- HGO 4G LTE: For GSM 900 & 1800, PCS, DECT, UMTS and W-LAN 2.4 systems, LTE

MULTI-BAND Omnidirectional



Electrical Data	HGO 4G LTE Improved	HGO 433-868
Type	Multi Band Dipole Array	
Frequency Range @ SWR ≤ 2	790-960 MHz (GSM 900, LTE 800) & 1.71-2.17GHz (GSM 1.8,PCN,DECT,UMTS) & 2.4-2.7 GHz (W-LAN 2.4, LTE 2.6)	415-465 MHz (ISM 433 MHz) & 815-890 MHz (ISM 868 MHz)
Impedance	50 Ω	
Radiation (H-plane)	360° omnidirectional	
Radiation (E-plane)	Beamwidth @ -3 dB: see diagrams	
Radiation angle deg.	0°	
Polarization	Linear Vertical	
Gain	5 dBi @ 790-960 MHz & 1.7-1.9 GHz, 6 dBi @ 1.9 - 2.17 GHz, 5+6 dBi @ 2.4-2.6 GHz	2 dBi @ 433 MHz, 4 dBi @ 868 MHz
Max Power (CW) @ 30° C	20 Watts @ 790 - 960 MHz, 10 Watts @ 1.9 - 2.17 GHz, 6 Watt @ 2.4 - 2.6 GHz	20 Watts
Cable Type/Length/Connector	White Low Loss / 50cm, 1.6 ft or 5m, 16.4 ft / SMA-male, other type on request	

Mechanical Data		
Housing & Radome Material	RAL 7035 Light Grey thermoplastic UV stabilized	
Bracket & Hardware Material	Galvanized Steel	
Wind Load / Resistance	36 N @ 150 Km/h / 200 Km/h, 124 mi/h	
Wind Surface	0.02 m ² , 0.21 ft ²	
Dimensions (approx.)	335 x 166 x 144 mm, 13.2 x 6.5 x 5.7 in with bracket	
Weight (approx.)	350 gr, 0.77 lb	
Operating Temperature	-20 °C to +80 °C	
Installation type	Mast: Ø25-42mm, Ø1-1.65in with U-bolt. Wall: with mounting screws (not included)	
P/N 50cm, 1.6 ft cable	2153904/05CO	2154104/05CO
P/N 5m, 16.4 ft cable	2153904/5CO	2154104/5CO

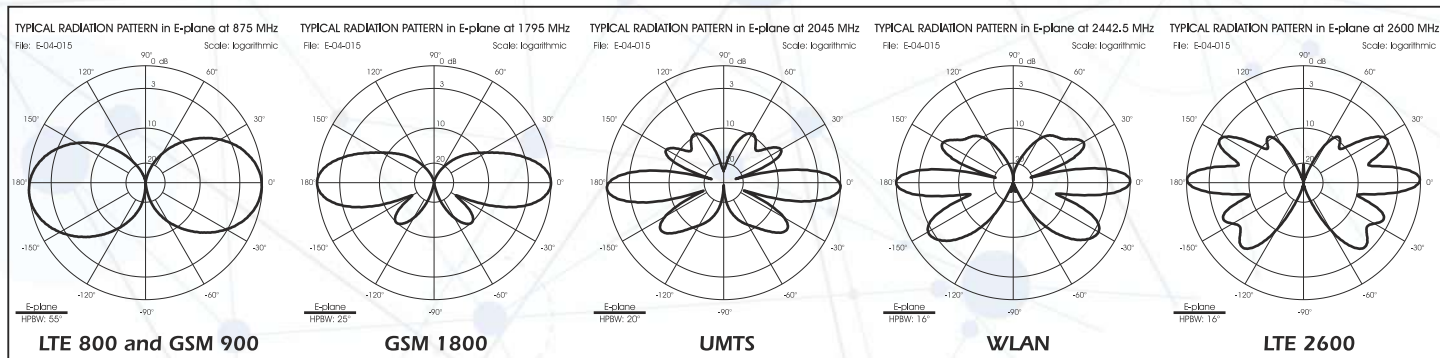
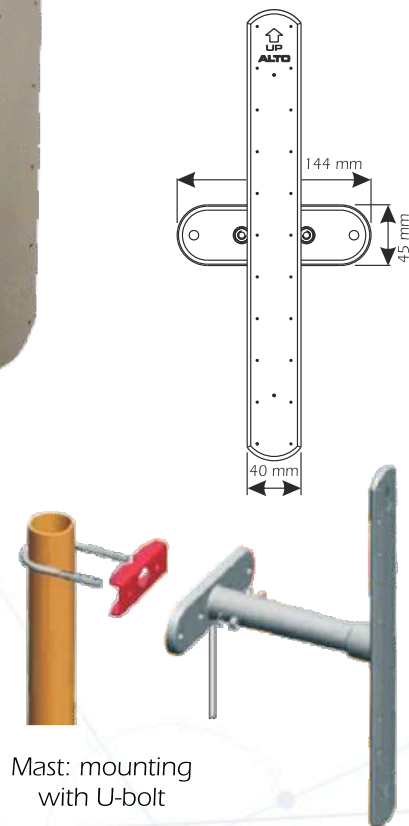

GP series Ground Plane Base Station

Features:

- # Base station antenna, Omnidirectional, Mono-band,
- # High-gain, no tuning required
- # Made of chromed brass, stainless steel whip, radials and hardware
- # Equipped with anodized aluminium bracket for an easy side mast installation
- # For ISM or GSM 900

GP 868 C
GP 900 C



GP 901 C

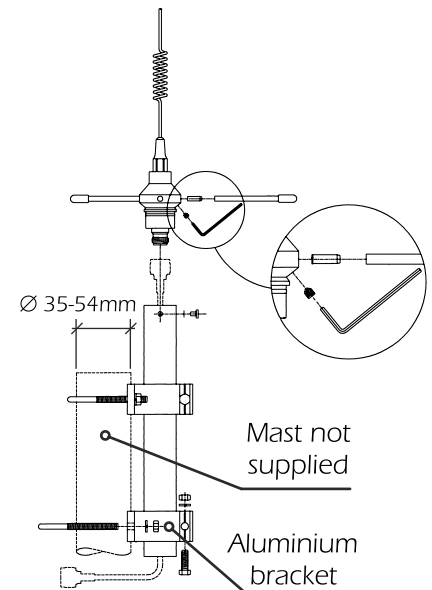

Electrical Data	GP 868 C	GP 900 C	GP 901 C
Type	1/4 λ + 1/2 λ Colinear	1/4 λ + 1/2 λ Colinear	1/4 λ + 2 x 1/2 λ Colinear
Frequency Range	835-900MHz @ SWR ≤ 2.0 (ISM)	870-960MHz @ SWR ≤ 2.6 (GSM 900)	870-960MHz @ SWR ≤ 2.8 (GSM 900)
Impedance	50 Ω		
Radiation (H-plane)	360° omnidirectional		
Radiation (E-plane) Beamwidth @ -3 dB	40° @ 868 MHz	40° @ 920 MHz	25° @ 920 MHz
Radiation angle deg.	7°	7°	6°
Polarization	Linear Vertical		
Gain	5.14 dBi	5.14 dBi	8.14 dBi
Max Power (CW) @ 30° C	50 Watts	50 Watts	50 Watts
Connector	N-female, gold plated central pin		

Mechanical Data

Housing & Radome Material	Aluminium, Chromed Brass, Stainless Steel 17/7 PH		
Bracket & Hardware Material	Aluminium, Stainless Steel		
Wind Load @ 150Km/h / Resistance	13N / 180Km/h, 112 mi/h	13N / 180Km/h, 112 mi/h	23N / 150Km/h, 93 mi/h
Wind Surface	0.015 m ² , 0.16 ft ²	0.01 m ² , 0.11 ft ²	0.02 m ² , 0.21 ft ²
Height (approx.)	600 mm, 2 ft	550 mm, 1.8 ft	800 mm, 2.6 ft
Radial Length (approx.)	90 mm, 3.5 in	75 mm, 3 in	75 mm, 3in
Weight (approx.)	650 gr, 1.4 lb		
Operating Temperature	-40 °C to +80 °C		
Installation type	Mast: Ø 35-54 mm, Ø 1.4-2.1 mm with V-bolt		
P/N	2107006.00/868	2107006.00	2107606.00

TYPICAL RADIATION PATTERN in E-plane at mid-band

File: E-03-012 GP 900 C Scale: logarithmic

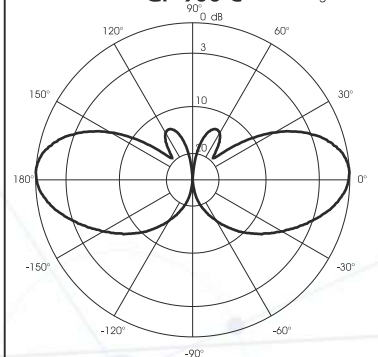

TYPICAL RADIATION PATTERN in E-plane at mid-band

File: E-03-014 GP 901 C Scale: logarithmic

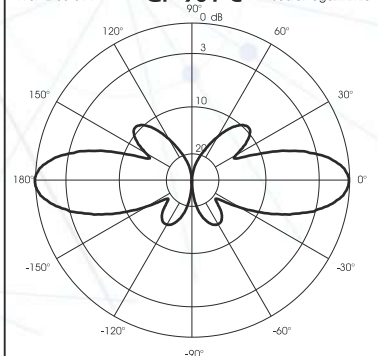

CX series Coaxial J-pole

OMNI 900 6 dBi OMNIdirectional antenna

Features:

- # Base station antenna, Omnidirectional, no tuning required
- # Mono-band, Protection from static discharges DC-ground
- # CX series: made of aluminium alloy 6063 T-832
- Omni 900 6 dBi: made of brass, copper and fiberglass
- # CX 840: for AMPS system
- CX 868: for ISM system
- CX 900: for GSM 900 system
- Omni 900 6 dBi: for GSM 900, high gain

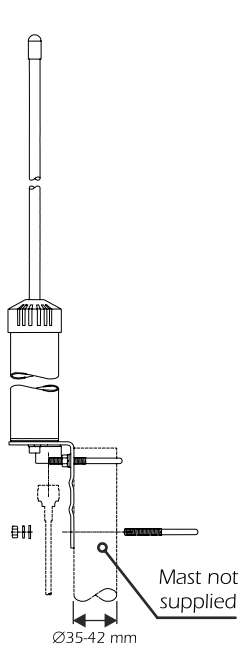

CX 840
CX 868
CX 900

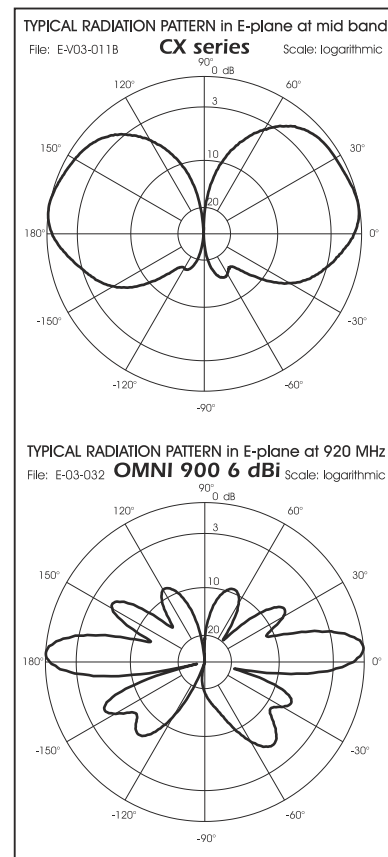

OMNI 900 6 dBi

Electrical Data	CX 840	CX 868	CX 900	OMNI 900 6 dBi
Type		3/4 λ Coax J-pole		3 x 1/2 λ Colinear dipole array
Frequency Range	824 - 894 MHz @ SWR ≤ 2.8 (AMPS system)	845 - 885 MHz @ SWR ≤ 1.5 (868 ISM system)	880 - 960 MHz @ SWR ≤ 2.6 (GSM 900 system)	868 - 960 MHz @ SWR ≤ 2.0 (ISM, GSM 900 system)
Impedance	50 Ω			
Radiation (H-plane)	360 ° Omnidirectional			
Radiation (E-plane) Beamwidth @ -3 dB	70° @ 920 MHz			18° @ 920 MHz
Radiation angle deg.	10°			5°
Polarization	Linear Vertical			
Gain	4.15 dBi			6 dBi
Max Power (CW) @ 30° C	100 Watts			20 Watts
Grounding Protection	All metal parts are DC-grounded, the inner conductor shows a DC-short			
Cable Type / Length	/			White Low Loss / 5m, 16.4 ft
Connector	N-female			SMA-male, other on request
Mechanical Data				
Housing & Radome Material	Aluminium, Zamac, Brass			Fiberglass, Chromed brass
Bracket & Hardware Material	Galvanized Steel			Stainless steel
Wind Load @ 150 Km/h / Resistance	17 N / 180 Km/h, 112 mi/h			35 N / 120 Km/h, 75 mi/h
Wind Surface	0.01 m ² , 0.1 ft ²			0.034 m ² , 0.36 ft ²
Height (approx.)	390 mm, 1.28 ft	380 mm, 1.24 ft	370 mm, 1.2 ft	1045 mm, 3.4 ft
Weight (approx.)	470 gr, 1 lb			950 gr
Operating Temperature	-40 °C to +80 °C			-20 °C to +80 °C
Installation type	Mast: Ø 35-42 mm, Ø 1.4-1.65 in			With screws (not included)
P/N	2107401.00	2107501.00	2106601.00	2110420.80

SO-918-2, SO-918-2 M1 *Sirio Omnidirectional Antennas*

Features:

- # Base station antenna, Omnidirectional, Multi-band, Unity-gain
- # High quality PCB radiator protected by fiberglass tube
- # Protection from static discharges DC-ground, no tuning required
- # For ISM, GSM 900 & 1800, PCS, DECT and UMTS systems

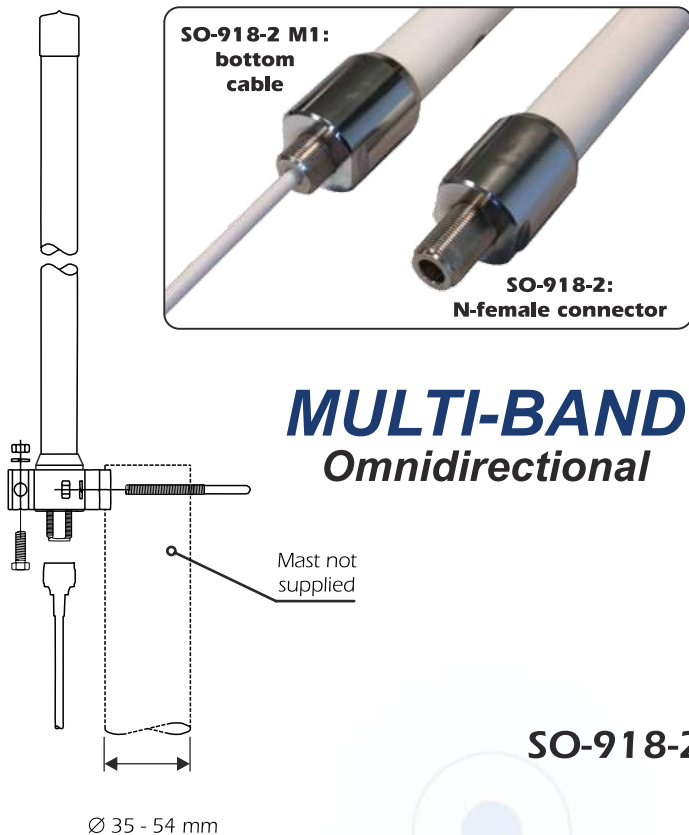

MULTI-BAND
Omnidirectional

SO-918-2

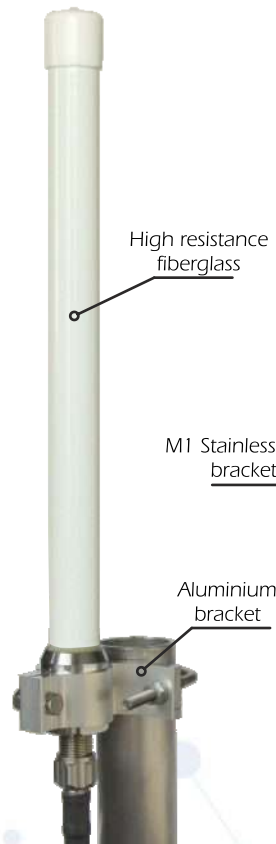

SO-918-2 M1

Electrical Data	SO-918-2	SO-918-2 M1
Type	1/2 λ Dipole	
Frequency Range @ SWR ≤ 2.0	868 - 960 MHz (ISM, GSM 900) &	1.71 - 2.17 GHz (GSM 1.8, PCN, DECT, UMTS)
Impedance	50 Ω	
Radiation (H-plane)	360° omnidirectional	
Radiation (E-plane) Beamwidth @ -3 dB	50°	
Radiation angle deg.	0°	
Polarization	Linear Vertical	
Gain	2.15 dBi	
Max Power (CW) @ 30° C	20 Watts	
Grounding Protection	All metal parts are DC-grounded, the inner conductor shows an open circuit	
Cable Type / Length	/	White Low Loss / 5m, 16.4 ft
Connector	N-female, gold plated central pin	SMA-male, other type on request
Mechanical Data		
Housing & Radome Material	Fiberglass, Chromed Brass, PCB	
Bracket & Hardware Material	Aluminium, Stainless steel	Stainless steel M1 bracket
Wind Load @ 150Km/h / Resistance	11 N / 200 Km/h, 124 mi/h	
Wind Surface	0.01 m ² , 0.11 ft ²	
Height (approx.)	257 mm, 0.84 ft	
Weight (approx.)	350 gr, 0.77 lb	
Operating Temperature	-20 °C to +80 °C	
Installation type	Mast: Ø35-54mm, 1.4-2.1in with V-bolt	Wall: with mounting screws (not included)
P/N	2110320.00	2110920.80

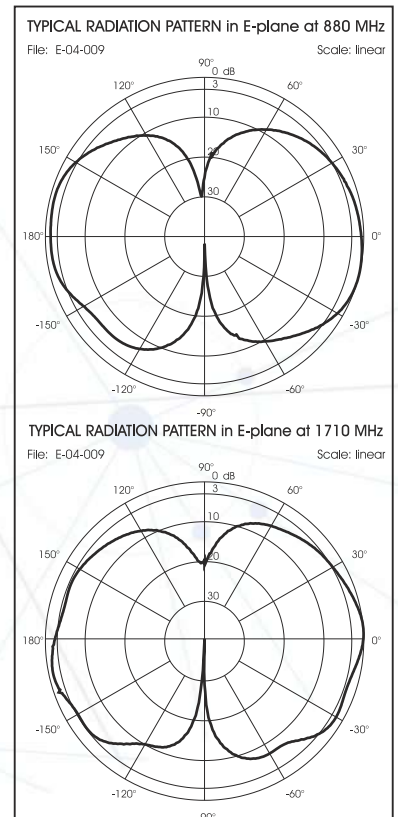

SO 868-915 *Sirio Omnidirectional*

SCO-868-4/6 *Sirio Colinear Omni*

Features:

- # Base station antenna
- # Omnidirectional, no tuning required
- # High quality PCB radiator protected by fiberglass tube
- # SO 868-915: For ISM 868 & 915 system
- SCO-868-4, SCO-868-6: for ISM 868



SCO-868-4
SCO-868-6

NEW MODELS

SO 868-915

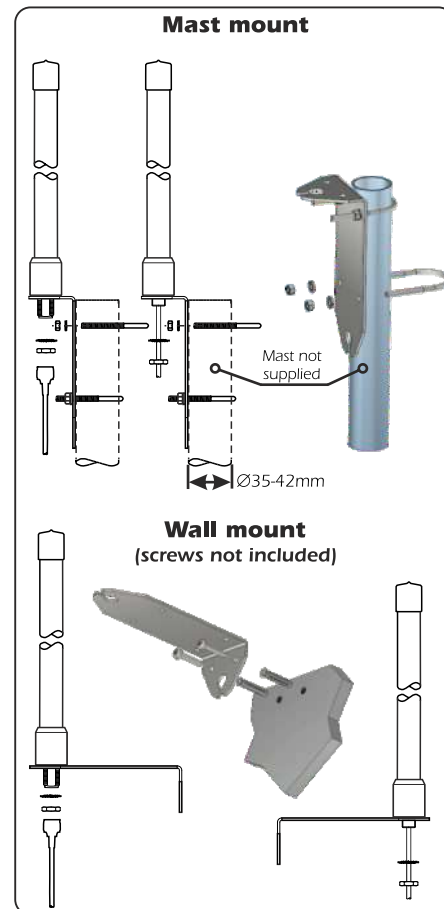

Electrical Data	SO 868-915	SCO-868-4 cable	SCO-868-6 cable	SCO-868-4 N-f	SCO-868-6 N-f
Type	1/2 λ Dipole	2 x 1/2 λ Colinear	3 x 1/2 λ Colinear	2 x 1/2 λ Colinear	3 x 1/2 λ Colinear
Frequency Range @ SWR ≤ 1.5	868 - 915 MHz	868 - 870 MHz	868 - 870 MHz	868 - 870 MHz	868 - 870 MHz
Impedance	50 Ω				
Detection DC resistance	10 KΩ	/	/	/	/
Radiation (H-plane)	360° omnidirectional				
Radiation (E-plane) Beamwidth @ -3 dB:	88°	32°	22°	32°	22°
Radiation angle deg.	0°				
Polarization	Linear Vertical				
Gain	0 dBd, 2.15 dBi	2.2 dBd, 4.3 dBi	4.1 dBd, 6.2 dBi	2.2 dBd, 4.3 dBi	4.1 dBd, 6.2 dBi
Max Power (CW) @ 30° C	20 Watts				
Cable Type / Length	White Low Loss cable / 5m, 16.4 ft			/	
Connector	SMA-male, other type on request			N-female, gold plated central pin	
Mechanical Data					
Housing & Radome Material	Fiberglass, PCB, Chromed Brass				
Bracket & Hardware Material	Galvanized steel				
Wind Load @ 150 Km/h, 93 mi/h	34 N	35 N	41 N	35 N	41 N
Wind Resistance	200 Km/h, 124 mi/h	140 Km/h, 87 mi/h	120 Km/h, 75 mi/h	140 Km/h, 87 mi/h	120 Km/h, 75 mi/h
Wind Surface	0.023 m ² ; 0.24 ft ²	0.0243 m ² ; 0.25 ft ²	0.03 m ² ; 0.32 ft ²	0.0243 m ² ; 0.25 ft ²	0.03 m ² ; 0.32 ft ²
Height (approx.)	290 mm, 0.95 ft	500 mm, 1.65 ft	770 mm, 2.5 ft	500 mm, 1.65 ft	770 mm, 2.5 ft
Weight (without bracket, approx.)	380 gr, 0.84 lb	380 gr, 0.84 lb	490 gr, 1.1 lb	280 gr, 0.6 lb	330 gr, 0.7 lb
Operating Temperature	-40 °C to +80 °C				
Installation type	M3 bracket:		Mast: Ø 35-42 mm, Ø 1.4-1.65 inch with U-bolt Wall: with screws (not included)		
P/N	available on request	2111620.80	2111720.80	2111620.00	2111720.00

SCO series

Sirio Colinear Omnidirectional

HIGH-GAIN
Omnidirectional

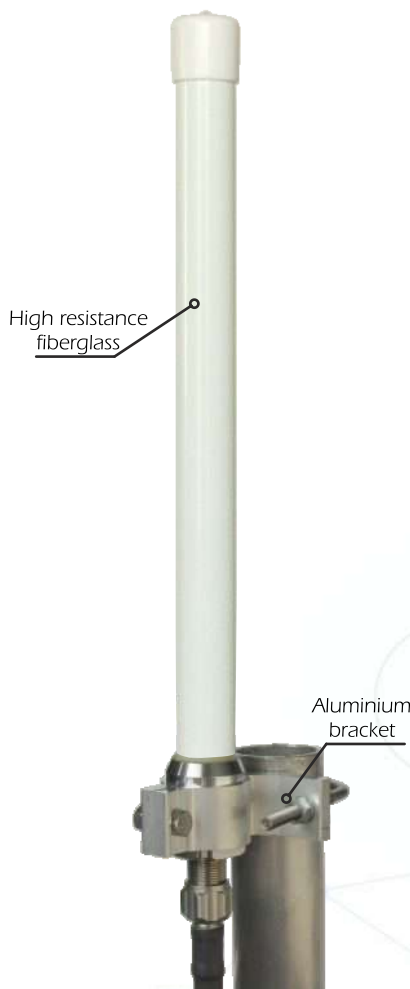

SCO-1.93-6 DECT

SCO-2-6 UMTS

SCO-2.4-6 W-LAN 2.4

SCO-3.3-7 WiMAX 3.3

SCO-5.47-10 W-LAN 5.47

SCO-2451 W-LAN 2.4 & 5 GHz

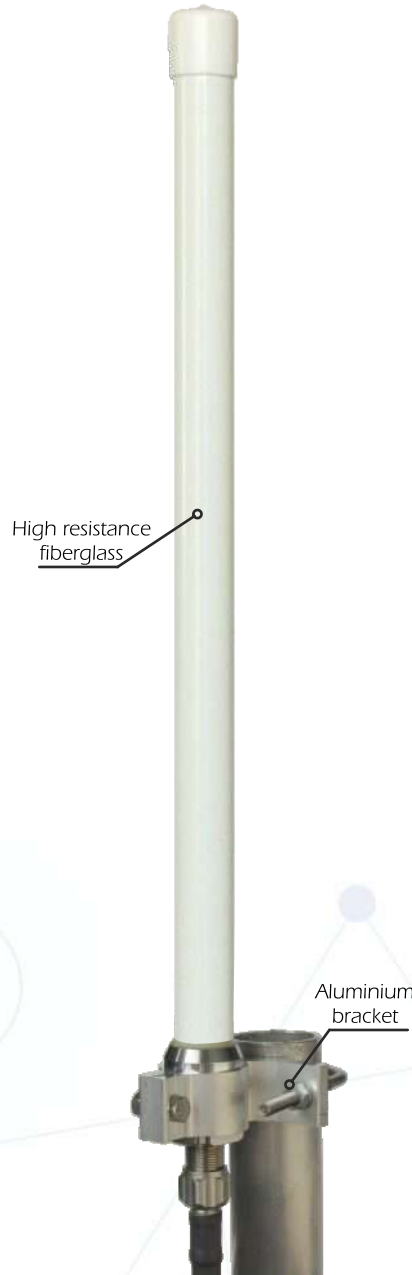

SCO-2.4-9 W-LAN 2.4

SCO-3.3-10 WiMAX 3.3

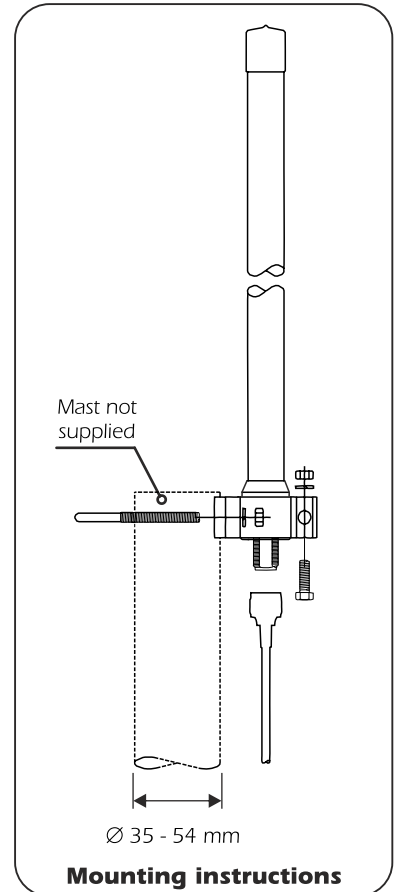

SCO series

Sirio Colinear Omnidirectional

Features:

- # Base station antenna, Omnidirectional, Mono-band, High-gain, no tuning required
- # High quality PCB radiator protected by fiberglass tube
- # For DECT or UMTS or W-LAN 2.4 (IEEE 802.11b) or WiMAX 3.3 or W-LAN 5.15 (IEEE 802.11a)

Electrical Data	SCO-1.93-6	SCO-2-6	SCO-2.4-6	SCO-2.4-9	SCO-3.3-7	SCO-3.3-10	SCO-5.47-10	SCO-2451
Type: Dipole Array	3 x 1/2 λ	3 x 1/2 λ	3 x 1/2 λ	7 x 1/2 λ	3 x 1/2 λ	7 x 1/2 λ	7 x 1/2 λ	Colinear Array
Frequency Range	1.88-1.98 GHz @ SWR ≤ 1.5 (DECT)	1.92-2.17 GHz @ SWR ≤ 2.6 (UMTS)	2.3 - 2.5 GHz @ SWR ≤ 1.5 (W-LAN)	2.4-2.485 GHz @ SWR ≤ 1.5 (W-LAN)	3.3 - 3.8 GHz @ SWR ≤ 1.5 (WiMax)	3.3 - 3.8 GHz @ SWR ≤ 1.5 (WiMax)	5.47- 5.875 GHz @ SWR ≤ 1.5 (W-LAN)	2.4- 2.485 GHz & 5.15-5.875 GHz (W-LAN 2.4 - 5)
Impedance	50 Ω							
Radiation (H-plane)	360° omnidirectional							
Radiation (E-plane) Bw @-3dB	27° @ 1.93 GHz	27° @ 2.045 GHz	22° @ 2.442 GHz	10° @ 2.442 GHz	17° @ 3.55 GHz	10° @ 3.55 GHz	10° @ 5.672 GHz	30° & 20°
Radiation angle deg.	0°							
Polarization	Linear Vertical							
Gain	6 dBi	6 dBi	6 dBi	9 dBi	7 dBi	10 dBi	10 dBi	4 & 6 dBi
Max Power (CW) @ 30° C	20 Watts	20 Watts	20 Watts	20 Watts	10 Watts	10 Watts	20 Watts	10 Watts
Grounding Protection	All metal parts are DC-grounded, the inner conductor show a DC-short							Open circuit
Connector	N-female, gold plated central pin							

Mechanical Data

Housing & Radome Material	Fiberglass, Aluminium, Chromed Brass, PCB							
Bracket & Hardware Material	Aluminium, Stainless Steel							
Wind Load @ 150 Km/h	11 N	11 N	10 N	20 N	10 N	20 N	11 N	9 N
Wind Resistance	200Km/h,124mi/h	200Km/h,124mi/h	200Km/h,124mi/h	200Km/h,124mi/h	200Km/h,124mi/h	200Km/h,124mi/h	200Km/h,124mi/h	200Km/h,124mi/h
Wind Surface	0.01 m ² , 0.11 ft ²	0.01 m ² , 0.11 ft ²	0.01 m ² , 0.11 ft ²	0.02 m ² , 0.21 ft ²	0.01 m ² , 0.11 ft ²	0.02 m ² , 0.21 ft ²	0.01 m ² , 0.11 ft ²	0.007 m ² , 0.08 ft ²
Height (approx.)	400 mm, 1.3 ft	400 mm, 1.3 ft	325 mm, 1.07 ft	630 mm, 2.1 ft	325 mm, 1.07 ft	630 mm, 2.1 ft	400 mm, 1.3 ft	255 mm, 0.83 ft
Weight (approx.)	360 gr, 0.8 lb	360 gr, 0.8 lb	350 gr, 0.77 lb	415 gr, 0.9 lb	350 gr, 0.77 lb	410 gr, 0.9 lb	365 gr, 0.8 lb	330 gr, 0.72 lb
Operating Temperature	-40 °C to +80 °C							
Installation type	Mast: Ø 35-54 mm, Ø 1.4-2.1 in with V-bolt							
P/N	2110620.00	2110520.00	2130220.00	2130320.00	2132520.00	2132620.00	2132020.00	2132120.00

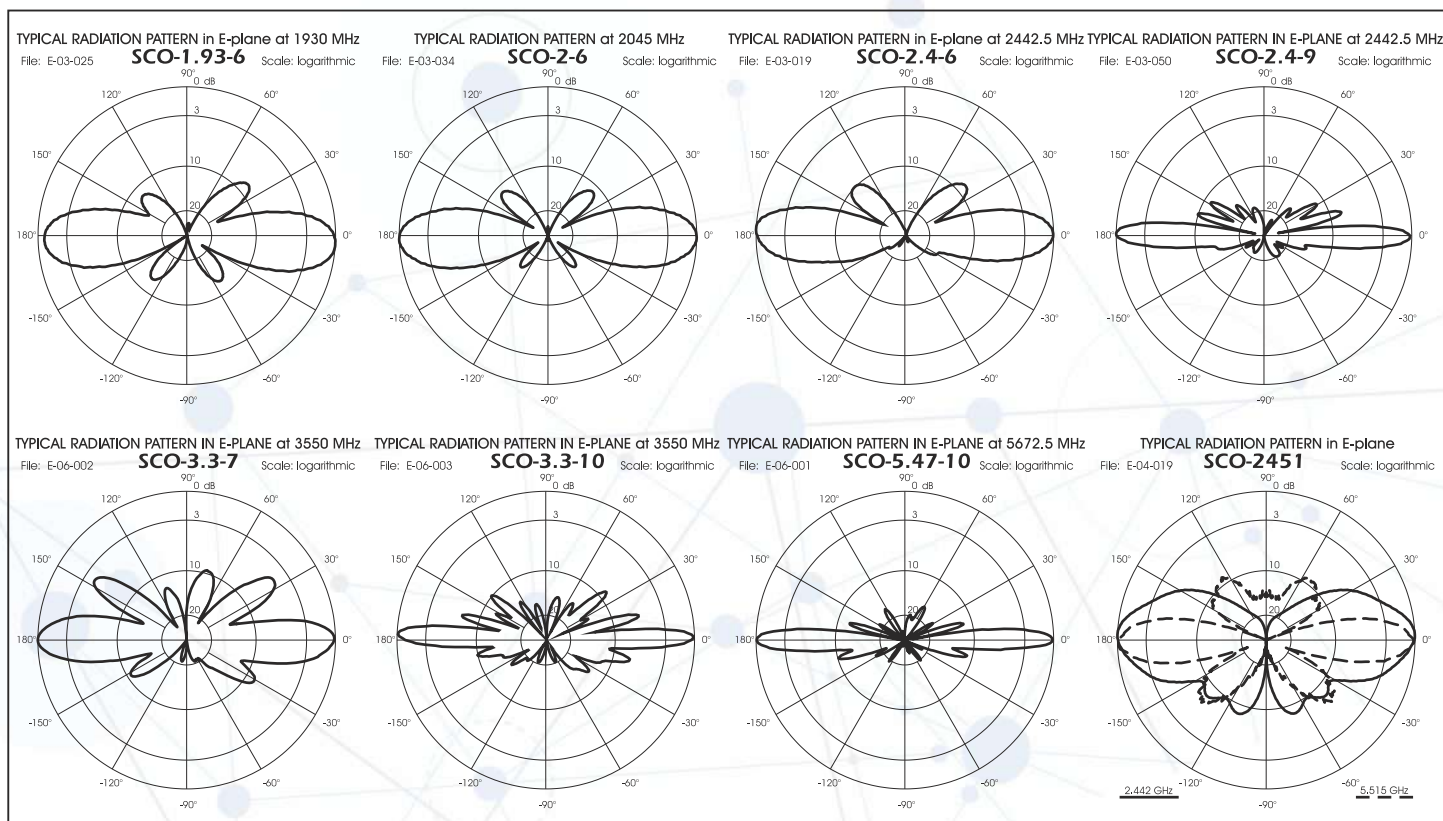

SCM-918-2

Sirio Ceiling Mount, Multi Band

Features:

- # Indoor Base station antenna, Omnidirectional, Multi-band, Unity-gain, no tuning required
- # Paintable high impact polystyrol radome
- # Protection from static discharges DC-ground
- # For GSM 900 & 1800, PCS, DECT and UMTS systems

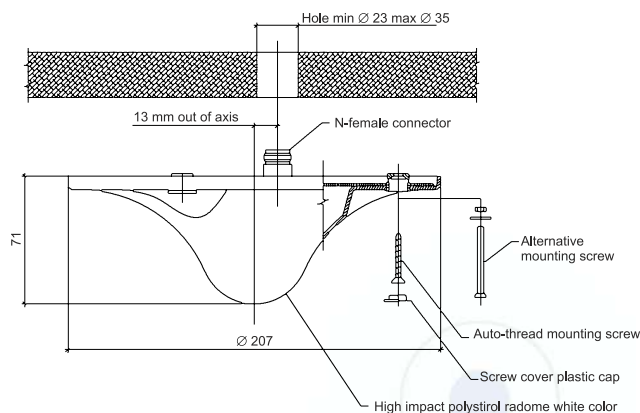

MULTI-BAND

Ceiling mount

Electrical Data	SCM-918-2
Type	1/4 λ both bands
Frequency Range	876 - 960 MHz @ SWR ≤ 1.8 (GSM 900, ISM 868, ISM 915) & 1.71 - 2.17 GHz @ SWR ≤ 1.6 (GSM 1.8, PCN, DECT, UMTS)
Impedance	50 Ω
Radiation (H-plane)	360° omnidirectional
Radiation (E-plane) Beamwidth @ -3 dB	66° @ 918 MHz, 55° @ 1.8/1.92/2 GHz
Radiation angle deg.	-20° @ 918 MHz, -45° @ 1.8/1.92/2 GHz
Polarization	Linear Vertical
Gain	2.15 dBi
Max Power (CW) @ 30° C	50 Watts
Grounding Protection	All metal parts are DC-grounded, the inner conductor shows a DC-schort
Connector	N-female Panel, gold plated central pin
Mechanical Data	
Housing & Radome Material	Aluminium, Brass, High impact polystyrol White (paintable) Radome
Diameter (approx.)	207 mm, 8.2 in
Height (approx.)	71 mm, 2.8 in (without connector)
Weight (approx.)	340 gr, 0.75 lb
Operating Temperature	-40 °C to +80 °C
Installation type	On ceiling (screws enclosed)
P/N	2110703.00

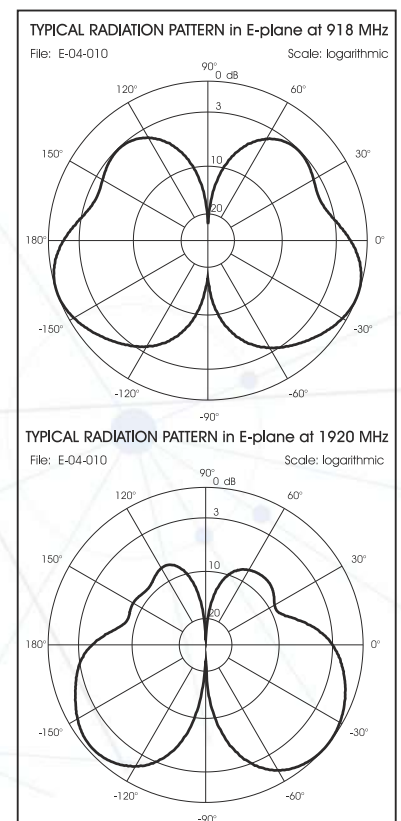

PA-2.4-2 *Portable Antennas*

Features:

- # Base station internal use antenna, Omnidirectional,
- # Unity-gain, no tuning required
- # 90° inclination adjustable radiator
- # High quality radiator protected by thermoplastic material
- # For W-LAN 2.4 system



PA-2.4-2 TNC



PA-2.4-2 SMA

90° Inclination
Omnidirectional

Electrical Data	PA-2.4-2 TNC	PA-2.4-2 SMA
Type	1/2 λ Dipole	
Frequency Range	2.4 - 2.485 GHz (W-LAN 2.4)	
Impedance	50 Ω	
Radiation (H-plane)	360° omnidirectional	
Radiation (E-plane) Beamwidth @ -3 dB	60° @ 2.4425 GHz	
Radiation angle deg.	0°	
Polarization	Linear Vertical	
Gain	2.15 dBi	
Max Power (CW) @ 30° C	1 Watt	
Connector	TNC-male rev. pol. 90° inclination	SMA-male rev. pol. 90° inclination
Mechanical Data	Chromed Brass, Thermoplastic	
Housing & Radome Material	Chromed Brass, Thermoplastic	
Dimensions (approx.)	Ø14.5x141 mm, Ø 0.6x5.5 in	Ø 10x108 mm, Ø 0.4x4.2 in
Weight (approx.)	25 gr, 0.055 lb	
Operating Temperature	-20 °C to +50 °C	
Installation type	Internal use only	
P/N	2450002.21RP	2450102.15RP

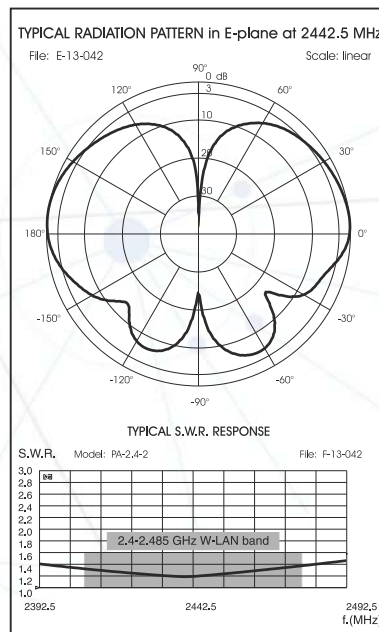

WY series

Wide-band Yagi 300-500 MHz

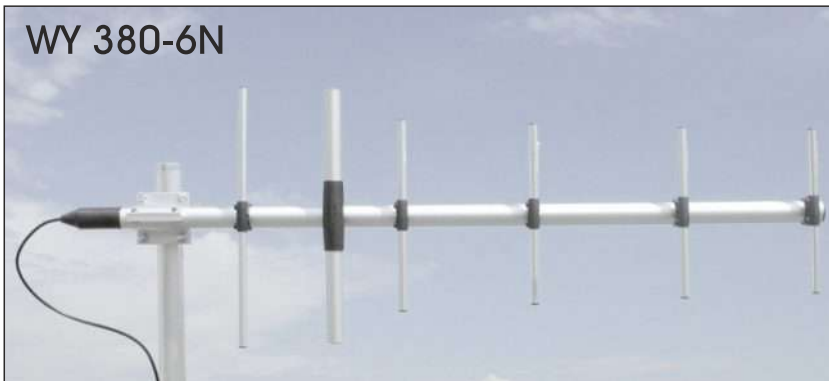
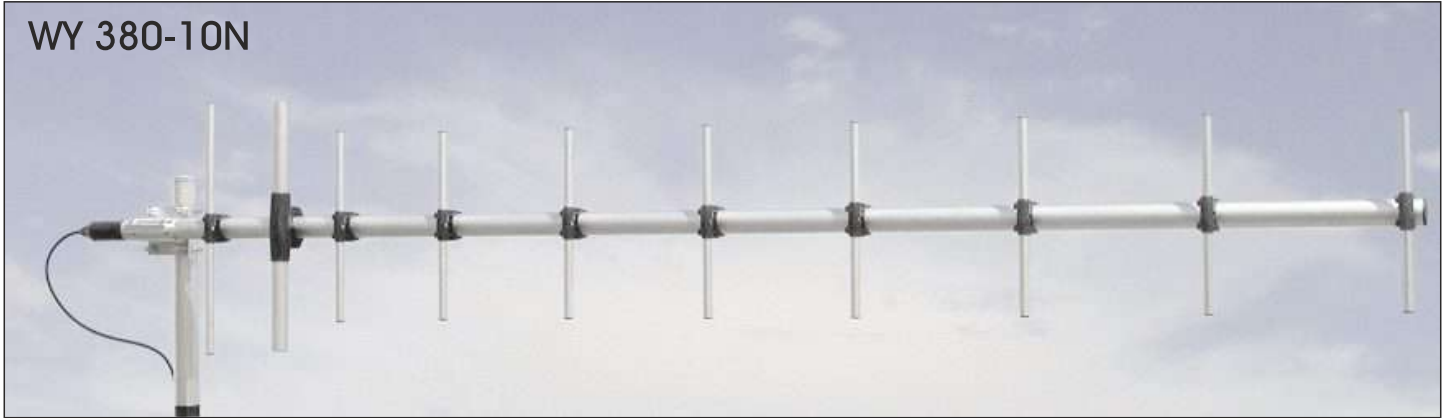

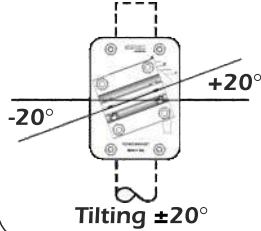
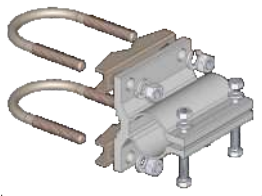
<p>Optional Tilting bracket P/N 2519803.00</p> <p>Materials & Hardware: zinc plated steel Dimensions: 110 x 150 x 6 mm. Weight: 800 gr</p>  <p>Tilting $\pm 20^\circ$</p>	<p>Standard Mounting bracket</p> <p>Materials: extruded aluminum Hardware: stainless & zinc plated steel Dimensions : 80 x 76 x 65 mm Weight: 460 gr</p> 
--	---



WIDE-BAND YAGI
New feed system for High simmetrical pattern
Completely computer designed for the best performances
Patent pending

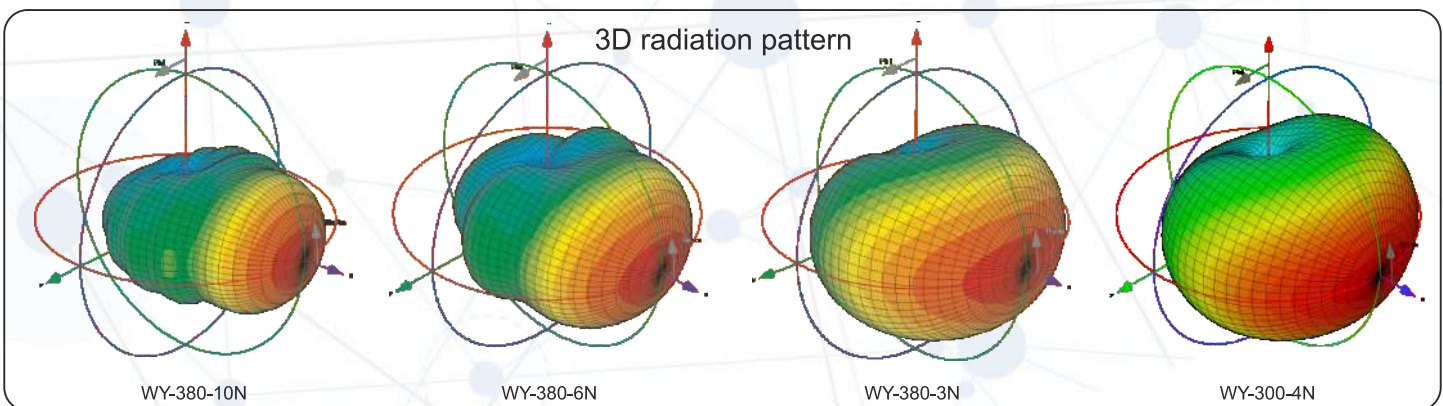

WY series Wide-band Yagi 300-500 MHz

Features:

- # Wide-band directional base station antenna. No tuning required
- # Exclusive feed system conceived for the highly symmetrical radiation pattern in both planes (E and H), patent pending applied
- # Completely computer designed to get the best performance of gain and front-to-back ratio in the band of interest
- # Made of anodized 6063-T5 aluminium, extruded aluminium bracket, rear mounting
- # N female connector protected by EPDM rubber cap for RG58 or RG213 cables
- # Stacked & bayed array for higher gain, Optional tilting bracket

Electrical Data	WY 300-4N	WY 380-3N	WY 380-6N	WY 380-10N
Type	4 elements Yagi	3 elements Yagi	6 elements Yagi	10 elements Yagi
Frequency Range	300-500 MHz @ SWR ≤ 2.0	380-440 MHz @ SWR ≤ 1.5	380-440 MHz @ SWR ≤ 1.5	380-440 MHz @ SWR ≤ 1.5
Impedance	50 Ω			
Radiation (H-plane) beamwidth @ -3 dB	150° @ 400 MHz	125°	70°	50°
Radiation (E-plane) beamwidth @ -3 dB	60° @ 400 MHz	65°	55°	45°
Front to back ratio	≥ 9 dB	≥ 17 dB	≥ 17 dB	≥ 18 dB
Polarization	Linear Vertical or Horizontal			
Gain	5.85 dBd - 8 dBi	4.85 dBd - 7 dBi	8.85 dBd - 11 dBi	11.85 dBd - 14 dBi
Max Power (CW) @30° C	150 Watts			
Grounding Protection	All metal parts are DC-grounded, the inner conductor shows a DC short			
Connector	N-female with rubber protection cap			

Mechanical Data

Materials	Anodized 6063-T5 Aluminium, EPDM rubber, thermoplastic UV stabilized, Chromed Brass			
Wind Load @ 150 km/h	60 N	65 N	100 N	150 N
Wind Resistance	180 Km/h, 112 mi/h	180 Km/h, 112 mi/h	150 Km/h, 93 mi/h	120 Km/h, 75 mi/h
Wind Surface	0.048 m ² , 0.51 ft ²	0.048 m ² , 0.51 ft ²	0.078 m ² , 0.83 ft ²	0.121 m ² , 1.3 ft ²
Dimensions W x H (approx.)	600 x 480 mm, 2 x 1.57 ft	565 x 400 mm, 1.9 x 1.3 ft	1180 x 400 mm, 3.9 x 1.3 ft	2125 x 400 mm, 7.0 x 1.3 ft
Turning radius (approx.)	470 mm, 1.54 ft	460 mm, 1.5 ft	1050 mm, 3.5 ft	1990 mm, 6.5 ft
Weight (approx.)	1300 gr, 2.87 lb	1130 gr, 2.5 lb	1540 gr, 3.5 lb	2120 gr, 4.7 lb
Operating temperature	-40° C to +60° C			
Mounting Mast	∅ 35 - 52 mm, 1.4-2.0 in			
Boom / Dipole / Element Diameter	∅ 32 mm, 1.3 in / ∅ 24 mm, 0.95 in / ∅ 12 mm, 0.5 in			
P/N	2113801/300	2113501/380	2113601/380	2113701/380

NEW MODEL

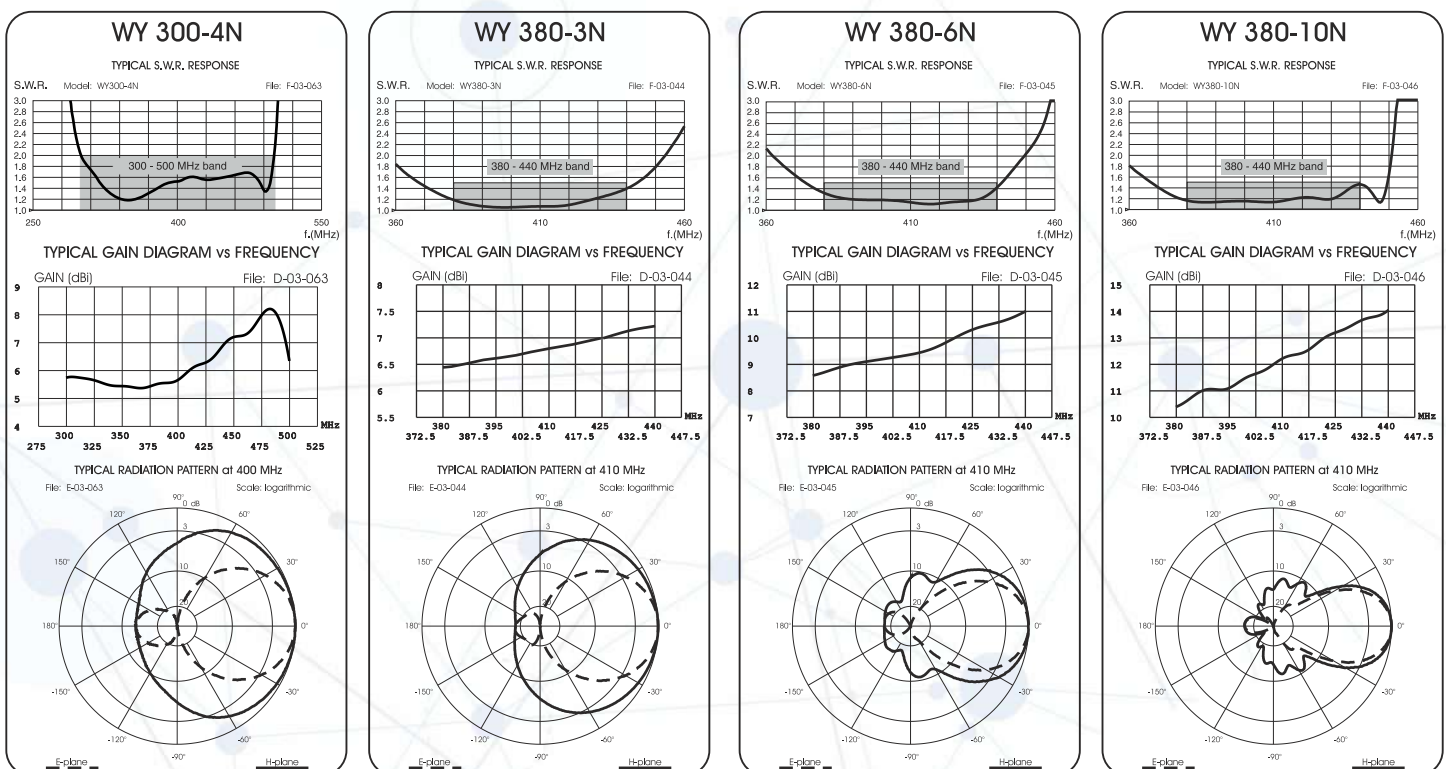

SMP series

High gain, Sirio Mini Panel

Features:

- # Compact base station antenna, High-gain
- # Indoor-Outdoor, Directional, Multi-band
- # High quality PCB radiator protected by UV stabilized radome
- # SMP 4G LTE: For LTE 800, GSM 900&1800,DCS, UMTS, LTE & W-LAN 2.4 systems
- SMP 24-33: W-LAN 2.4 & WiMAX 2.3 & 3.3

Features:

- # Compact base station antenna, High-gain
- # Indoor-Outdoor, Directional, Multi-band
- # 2x Wide band elements in single case conceived for MiMo systems
- # High quality PCB radiator protected by UV stabilized radome
- # SMP 4G LTE MiMo: For LTE 800, GSM 900&1800, DCS, UMTS, LTE & W-LAN 2.4 systems



**SMP 4G LTE
SMP 24-33**



**SMP 4G LTE
MIMO**

OPTIONAL TILTING BRACKET
 Mast: Ø35-50mm, Ø1.4-2 in
 with clamp included
 Wall: with mounting screws (not included)
P/N 2519703.00

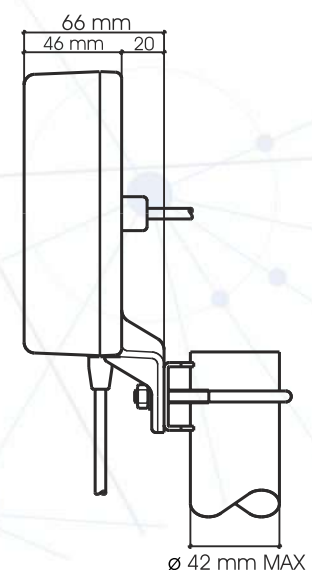
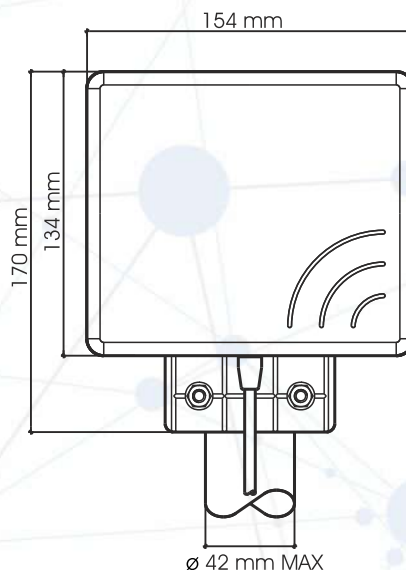
SMP series

High gain, Sirio Mini Panel

Electrical Data	SMP 4G LTE	SMP 4G LTE MiMo	SMP 24-33
Type	Mini Panel Antenna for Indoor or Outdoor use	Directional Mini Panel- 2 wideband elements	
Frequency Range @ SWR ≤2	790 - 960 MHz (LTE 800, GSM 900) & 1.71 - 2.7 GHz (DCS, UMTS, LTE, WLAN)	790 - 960 MHz (LTE 800, GSM 900) & 1.71 - 2.7 GHz (DCS, UMTS, LTE, WLAN)	2.3 - 2.7 GHz (W-LAN 2.4, Wi-MAX 2.3) & 3.3 - 3.8 GHz (Wi-MAX 3.3)
Impedance	50 Ω		
Radiation Beamwidth @ -3dB	see Typical Radiation Pattern		
Front to back ratio	≥12 dB @ 790-960 MHz. ≥16 @ 1.71-1.88GHz ≥20 dB @ 1.92-2.17 GHz. ≥10 @ 2.3-2.7 GHz	≥ 10 dB @ 790-960 MHz ≥ 15 dB @ 1.71-2.7 GHz	≥ 15 dB @ 2.3-2.7 GHz ≥ 20 dB @ 3.3-3.8 GHz
Polarization	Linear vertical		
Gain	6±7 dBi @ 790-960 MHz 9 dBi @ 1.71-2.17 GHz 8±9 dBi @ 2.3-2.7 GHz	5 dBi @ 790-960 MHz; 8 dBi @ 1.71-2.7 GHz (each element)	10 dBi @ 2.3-2.7 GHz; 13 dBi @ 3.3-3.8 GHz
Max Power (CW) @ 30° C	30 Watts @ 790-960 MHz 15 Watts @ 1.71-1.88 GHz 10 Watts @ 1.92-2.17 & 2.3-2.7 GHz	20 Watts @ 790-960 MHz; 8 Watts @ 1.71-2.7 GHz (each element)	6 Watts
Grounding Protection	All metal parts are DC-grounded, the inner conductor shows a DC-short	All metal parts are DC-grounded, the inner conductor shows a open-circuit	All metal parts are DC-grounded, the inner conductor shows a open-circuit
Cable Type / Length	White Low Loss /30cm, 1ft; other length on request	2 x RG316 / 30 cm, 1 ft	White Low Loss / 30cm, 1 ft
Connector	SMA-male, other type on request	2 x SMA-male, other type on request	SMA-male, other type on request
Mechanical Data			
Housing & Radome Material	RAL 7035 Light Grey thermoplastic UV stabilized		
Bracket & Hardware Material	Galvanized Steel		
Wind Load / Resistance	40 N @ 150 Km/h / 180 Km/h, 112 mi/h		
Wind Surface	0.02 m ² , 0.21 ft ²		
Dimensions (approx.)	154 x 134 x 46 mm, 6 x 5.3 x 1.8 mm without bracket		
Weight (approx.)	500 gr, 1.1 lb		
Operating Temperature	-40 °C to +80 °C		
Installation type	Mast: Ø 25-42 mm, Ø 1-1.6 in with U-bolt. Wall: with mounting screws (not included)		
P/N	2111003.00	2111403.00	2111303.00

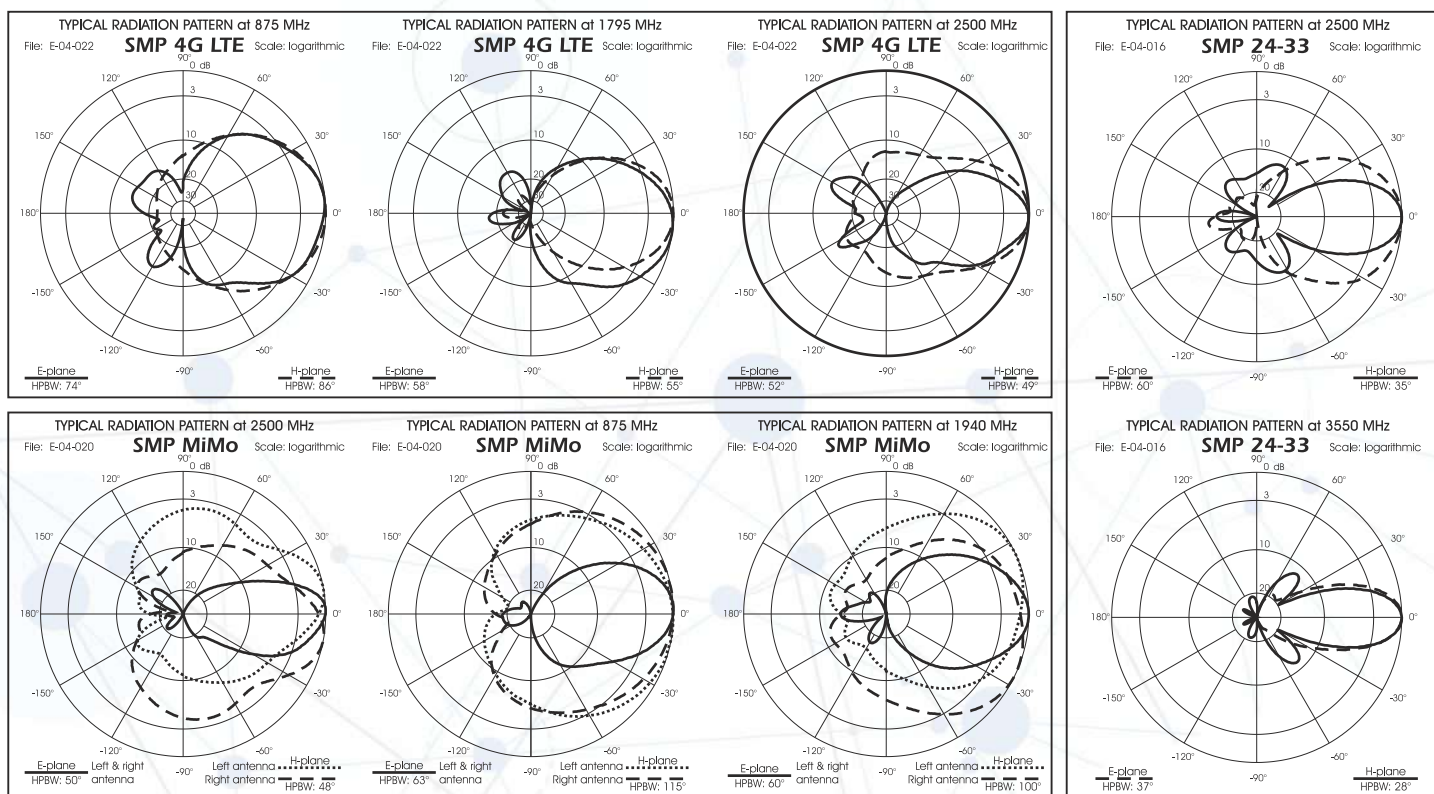

SLP-1.7:2.5-11 *Sirio Log Periodic*

Features:

- # Base station antenna, Directional,
- # Wide-band, High-gain, no tuning required
- # for DCS 1.8, PCS 1.8, DECT, UMTS and W-LAN 2.4 systems



WIDE-BAND
Directional

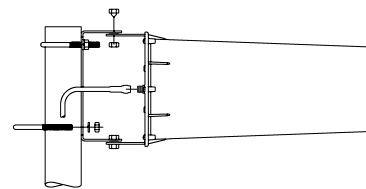

U-bolt (standard)

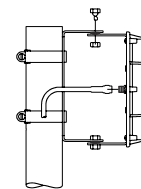

Clamp (optional)

Electrical Data	SLP-1.7:2.5-11
Type	Log Periodic Dipole array
Frequency Range	1.71 - 2.5 GHz @ SWR ≤ 2 (GSM 1.8, PCN, DECT, UMTS, W-LAN 2.4)
Impedance	50 Ω
Radiation (H-plane) Beamwidth @ -3 dB	58° frequency independent
Radiation (E-plane) Beamwidth @ -3 dB	46° frequency independent
Radiation angle deg.	0°
Front to back ratio	≥ 24 dB
Polarization	Linear Vertical
Gain	11.1 dBi
Max Power (CW) @ 30° C	50 Watts
Grounding Protection	All metal parts are DC-grounded, the inner conductor shows a DC-short
Connector	SMA-female panel

Mechanical Data	
Housing & Radome Material	Brass, Aluminium, White ABS UV stabilized
Bracket & Hardware Material	Galvanized Steel
Wind Load / Resistance	61 N @ 150 Km/h / 180 Km/h, 112 mi/h
Wind Surface	0.04 m ² , 0.43 ft ²
Dimensions (approx.)	345 x 135 x 73 mm, 13.6 x 5.3 x 2.9 in
Turning radius (approx.)	310 mm, 12.2 in
Weight (approx.)	400 gr, 088 lb
Operating Temperature	-40 °C to +80 °C
Installation type	Mast: Ø 35-42 mm, Ø 1.4-1.65 in with U-bolt; Clamp: Ø 25-70 mm, Ø 1-2.75 in (optional); Wall: with mounting screws (not included)
P/N	2130103.00

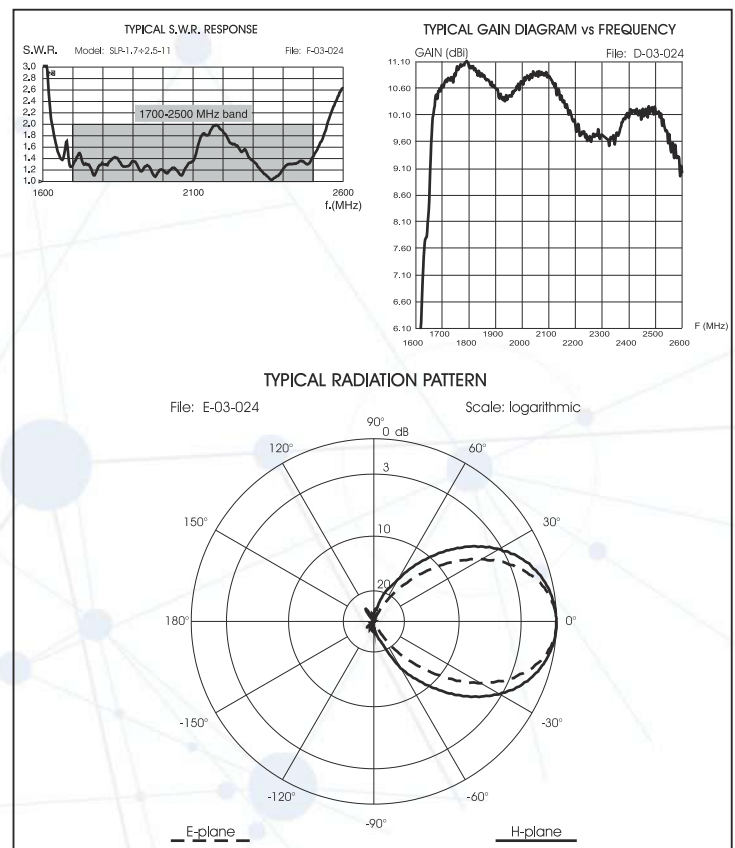

SPH-1.5:6-17 *Sirio Planar Horn*

Features:

- # Base station antenna, Directional,
- # Wide-band, High-gain, no tuning required
- # for DCS 1.8, PCS 1.8, DECT, UMTS, W-LAN 2.4 & 5.47



WIDE-BAND
Directional

Electrical Data	SPH-1.5:6-17
Type	Wide Band PCB antenna
Frequency Range	1.5-6 GHz @ SWR ≤ 1.8 (GSM 1.8, PCN, DECT, UMTS, W-LAN 2.4 & 5.47, WiMAX 2.3 & 3.3)
Impedance	50 Ω
Radiation (H-plane) Beamwidth @ -3 dB	see diagram
Radiation (E-plane) Beamwidth @ -3 dB	see diagram
Radiation angle deg.	0°
Front to back ratio	≥ 20 dB
Polarization	Linear Vertical
Gain	17 dBi @ 6 GHz
Max Power (CW) @ 30° C	15 Watts @ 1.5-4 GHz, 10 Watts @ 4-6 GHz
Grounding Protection	All metal parts are DC-grounded, the inner conductor show an open circuit
Connector	SMA-female panel
Mechanical Data	
Housing & Radome Material	PCB, Aluminium, White ABS UV stabilized
Bracket & Hardware Material	Galvanized Steel
Wind Load / Resistance	61 N @ 150 Km/h / 180 Km/h, 112 mi/h
Wind Surface	0.04 m ² , 0.43 ft ²
Dimensions (approx.)	345 x 135 x 73 mm, 13.6 x 5.3 x 2.9 in
Turning radius (approx.)	310 mm, 12.2 i
Weight (approx.)	450 gr, 1 lb
Operating Temperature	-40 °C to +80 °C
Installation type	Mast: Ø 35-42 mm, Ø 1.4-1.65 in with U-bolt; Clamp: Ø 25-70 mm, Ø 1-2.75 in (optional); Wall: with mounting screws (not included)
P/N	2130003.00

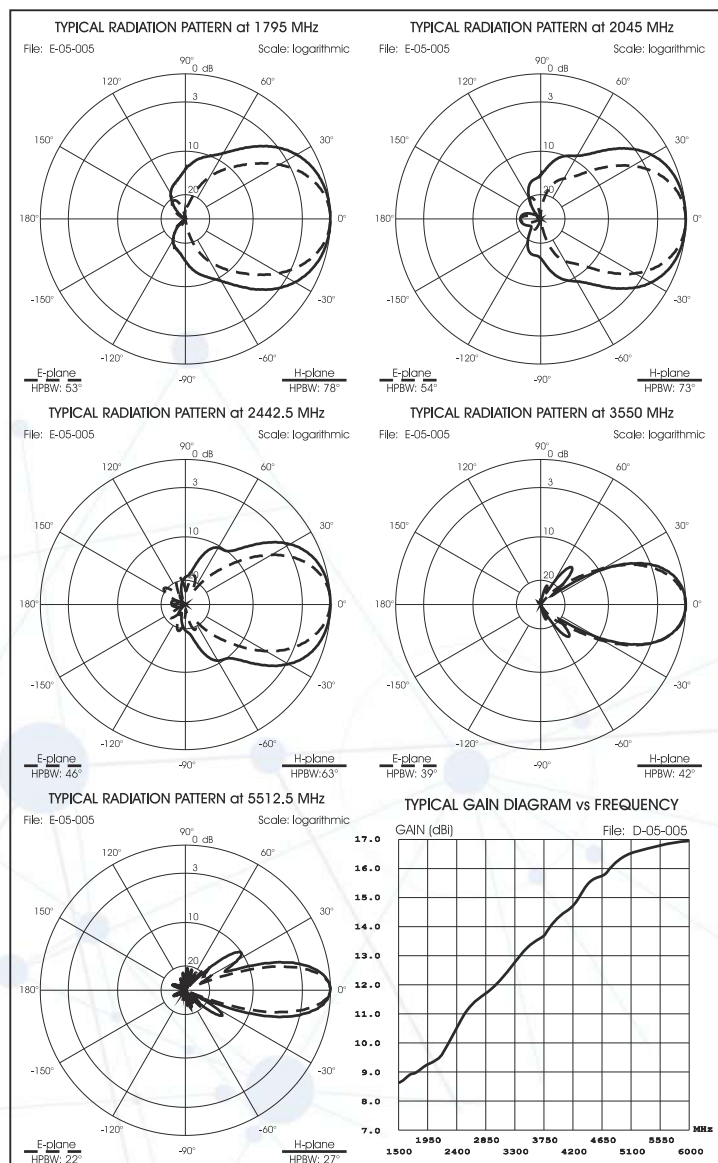

SY 906, SY 910 *Sirio Yagi Antenna*

UP-GRADED

Features:

- # Base station antenna, Directional
- # Mono-band, High-gain, no tuning required
- # Protection from static discharges DC-ground
- # Made of anodized aluminium alloy
- # For AMPS, ISM and GSM 900 systems
- # UP-GRADED: frequency extended from 698 MHz (LTE 700)

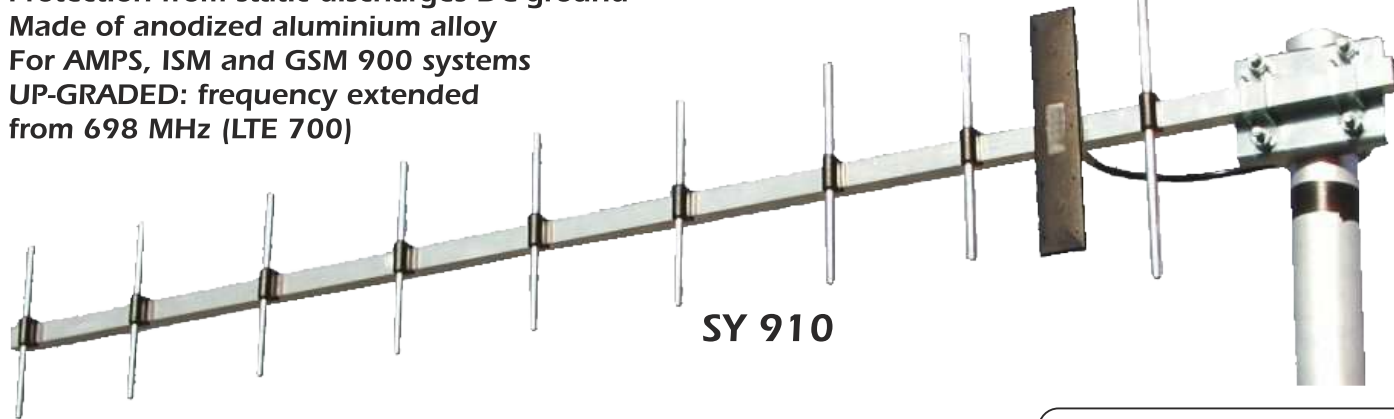

SY 910

HIGH-GAIN
Directional



SY 906

FT-4

Optional "FT-4" Fixing Bracket
 Top Size for antenna fitting: $\varnothing 38 \times 100 \text{mm}$, $\varnothing 3.1 \times 3.9 \text{in}$
 Bottom Size: $2 \times \varnothing 9 \text{mm}$, 0.35in wall fitting (screws not included)
 Weight (approx.): 780gr, 1.7 lb. Material: Galvanized Steel,
 FT-4 2513404.00

Electrical Data	SY 906	SY 910
Type	6 elements yagi antenna	10 elements yagi antenna
Frequency Range @ SWR ≤ 1.4	698 - 960 MHz (LTE 700, ISM, AMPS, GSM 900)	
Impedance	50 Ω	
Radiation (H-plane) Beamwidth @ -3 dB	66° @ 880 MHz	44° @ 890 MHz
Radiation (E-plane) Beamwidth @ -3 dB	53° @ 880 MHz	38° @ 890 MHz
Radiation angle deg.	0°	
Front to back ratio	$\geq 12 \text{ dB @ } 698 - 880 \text{ MHz}$; $\geq 15 \text{ dB @ } 880 - 960 \text{ MHz}$	
Polarization	Linear Vertical	
Gain	11.5 dBi	15 dBi
Max Power (CW) @ 30° C	10 Watts	
Grounding Protection	All metal parts are DC-grounded, the inner conductor shows a DC-short	
Connector	FME-male	

Mechanical Data	Aluminium, PCB, Thermoplastic	
Housing & Radome Material	Aluminium, PCB, Thermoplastic	
Bracket & Hardware Material	Galvanized Steel	
Wind Load @ 150 Km/h / Resistance	27 N / 180 Km/h, 112 mi/h	48 N / 150 Km/h, 93 mi/h
Wind Surface	0.02 m ² , 0.21 ft ²	0.03 m ² , 0.32 m ²
Dimensions (approx.)	210 x 595 x 60 mm, 8.3 x 23.4 x 2.4 in	210 x 995 x 60 mm, 8.3 x 39.2 x 2.4 in
Turning radius (approx.)	580 mm, 22.8 in	960 mm, 37.8 in
Weight (approx.)	410 gr, 0.9 lb	500 gr, 1.1 lb
Operating Temperature	-20 °C to +80 °C	
Installation type	Mast: $\varnothing 25\text{-}42 \text{ mm}$, 1-1.6 in with U-bolt	
P/N	2109901.00	2110001.00

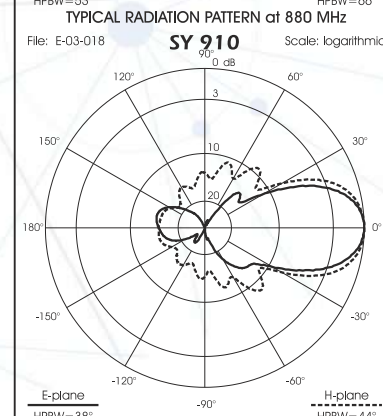
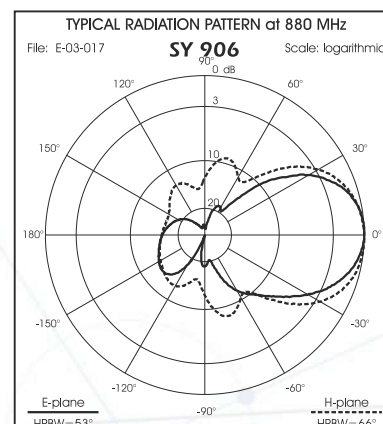

SDC-2.4-15 *Sirio Directional Cavity*

Features:

- # Base station antenna, Directional
- # Mono-band, High-gain, no tuning required
- # Protection from static discharges DC-ground
- # High quality brass radiator protected by thermoplastic UV stabilized radome
- # For W-LAN 2.4 system

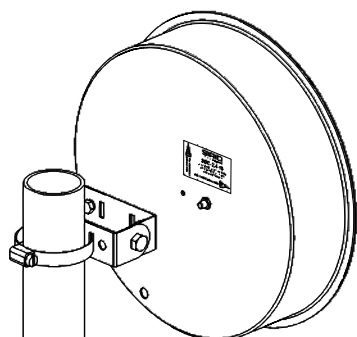

Mounting on the mast with clamp included

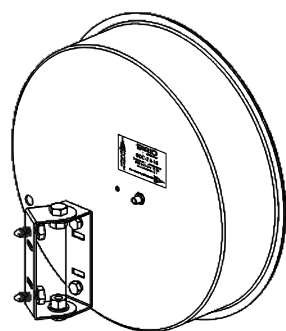

Mounting on the wall with screws (not included)



HIGH-GAIN Directional

Electrical Data	SDC-2.4-15
Type	Cavity Backed
Frequency Range @ SWR ≤ 1.6	2.4 - 2.485 GHz (W-LAN 2.4)
Impedance	50 Ω
Radiation (H-plane) Beamwidth @ -3 dB	33° @ 2442.5 GHz
Radiation (E-plane) Beamwidth @ -3 dB	27° @ 2442.5 GHz
Radiation angle deg.	0°, tiltable using enclosed tilting system
Front to back ratio	≥ 25 dB
Polarization	Linear Vertical or Horizontal
Gain	15 dBi
Max Power (CW) @ 30° C	20 Watts
Grounding Protection	All metal parts are DC-grounded, the inner conductor shows a DC-short
Connector	SMA-female

Mechanical Data	
Housing & Radome Material	Case: aluminium grey RAL 9007, Radome: light grey RAL 7035 thermoplastic UV stabilized
Bracket & Hardware Material	Aluminium, Stainless steel
Wind Load @ 150Km/h / Resistance	104 N / 160 Km/h, 99 mi/h
Wind Surface	0.06 m ² , 0.64 ft ²
Dimensions (approx.)	∅ 275 x 80 mm, ∅ 10.8 x 3.1 in without bracket
Weight (approx.)	720 gr, 1.6 lb
Operating Temperature	-20 °C to +80 °C
Installation type	Mast: ∅ 35-50 mm, ∅ 1.4-2 in with clamp included. Wall: with mounting screws (not included)
P/N	2111203.00

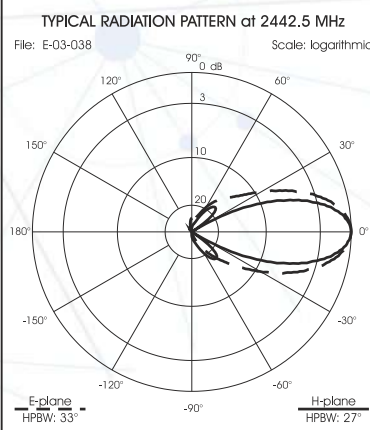
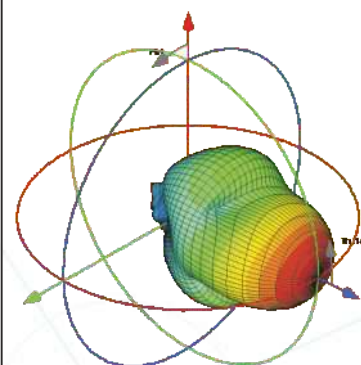
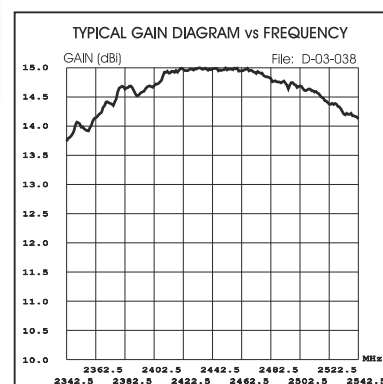

LPA series

Low Profile Antenna 380...470 MHz

Features:

- # Low profile mobile antenna designed for use on vehicles operating under severe height limitations such as buses, trains, trams, etc
- # Unity-gain omnidirectional mono-band
- # Protection from static discharges DC-Ground
- # Tunable by acting on internal screw

Electrical Data	LPA 380	LPA 420
Frequency Range	tunable 380...430 MHz	tunable 420...470 MHz
Impedance	50 Ω	
Radiation (H-plane)	360° Omnidirectional	
Radiation (E-plane)	Beamwidth @ -3 dB = 78°	
Polarization	Linear Vertical	
Gain	2 dBi (0 dB ref. to λ/4 whip) @ resonant freq.	
SWR @ res. freq.	Typically ≤ 1.5 @ resonant freq.	
Bandwidth @ SWR ≤ 2	Typically 2.5% @ center freq.	
Max Power (CW) @30°C	100 Watts	
Grounding Protection	All metal parts are DC-grounded, the inner conductor is coupled capacitively	
Cable Length / Type	1m, 3.2 ft / RG 58 C/U	
Connector	Standard: BNC-male, other on request	
Mechanical Data		
Materials	ABS UV stabilized, Aluminium, Brass	
Operating temperature	-40° C to +80° C	
Dimensions (approx.)	Ø 183 mm, 7.2 in / height 36 mm, 1.4 in	
Weight (approx.)	400 gr, 0.9 lb	
Mounting Hole	6x Ø 4.5 mm, 0.18 in + 2x Ø 16mm, 0.63 in	
P/N	2219003/380	2219003/420

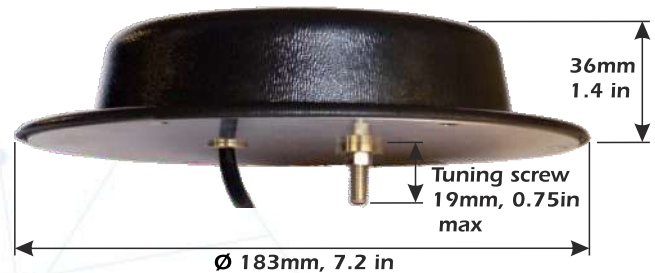

Remark: Optimum performance is achieved when the antenna is fitted on a metallic ground plane λ/2 square.

TYPICAL RADIATION PATTERN in E-plane at mid band
File: E-03-042 Scale: logarithmic

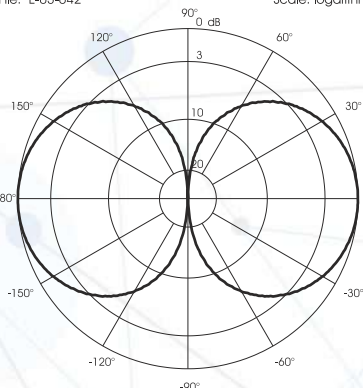

Mounting and tuning instructions

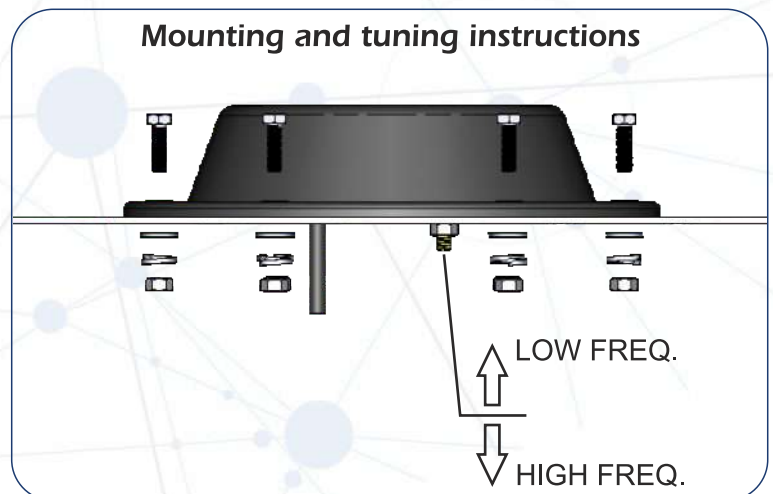

CELLFLEX

Features:

- # Mobile antenna, Omnidirectional, Multi-band
- # Flexible whip, detachable for car-wash
- # Anti-noise wind system, no tuning required
- # For AM-FM and GSM 900 / 1800

MULTI-BAND Omnidirectional

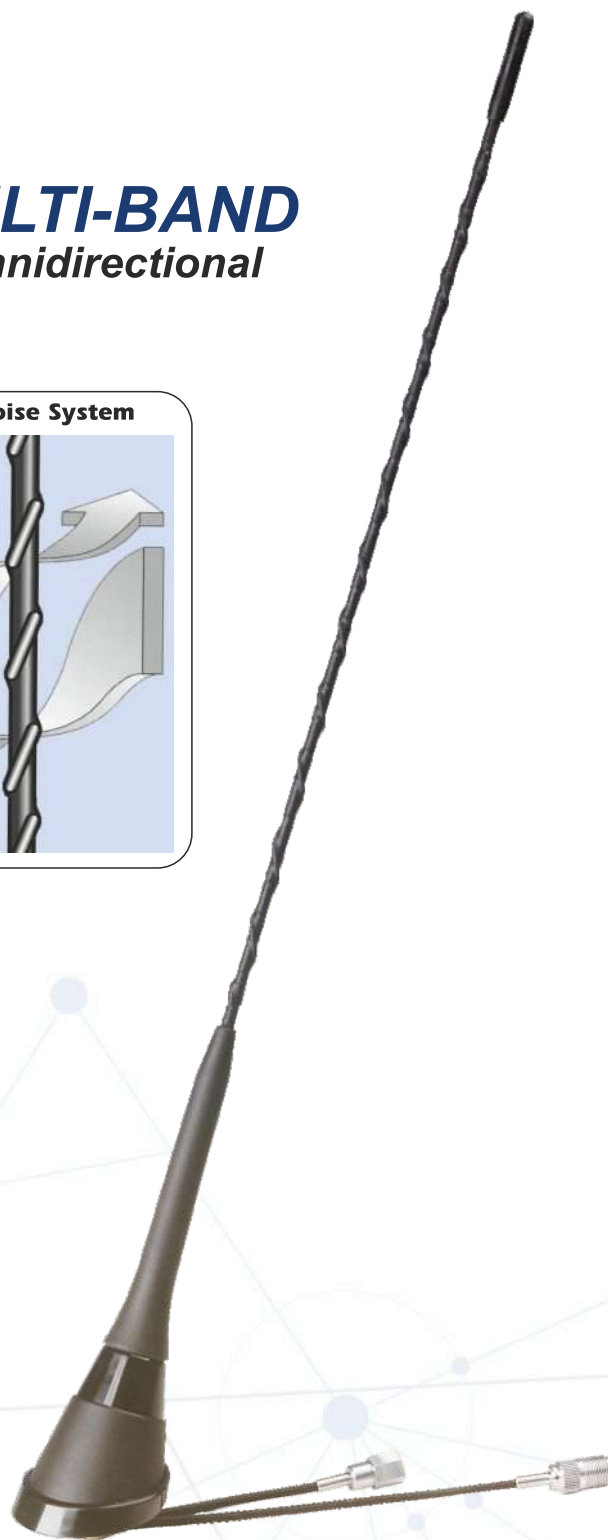
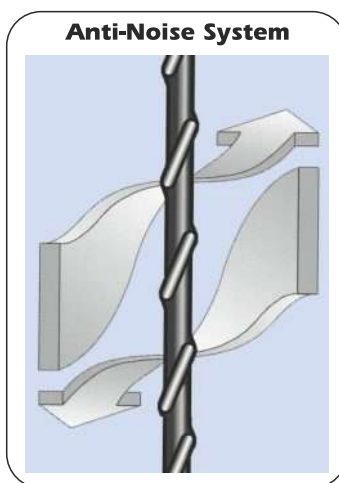
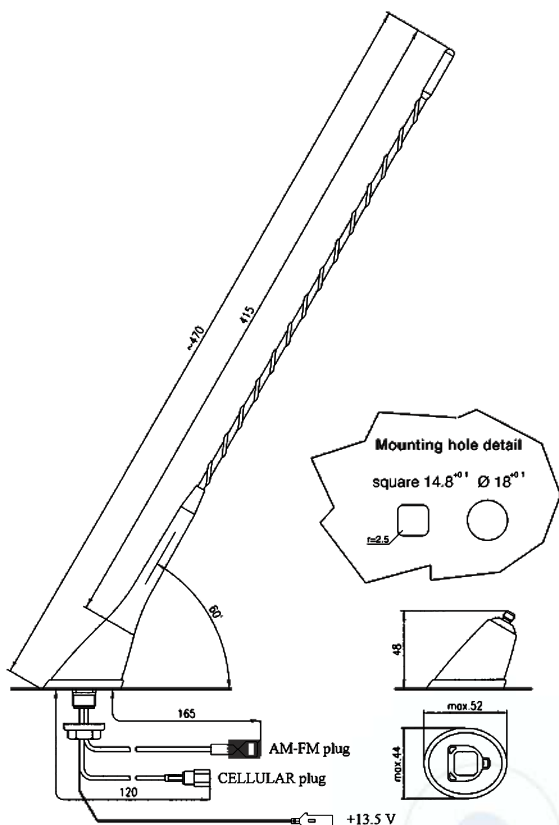

**CELLFLEX
AM-FM/900/1800**

Electrical Data	CELLFLEX AM-FM / 900 / 1800
Type	FM band: 1/4 λ helical loaded; GSM bands 900/1800: 1/4 λ
Frequency Range	AM: 0.15-1.6 MHz;; FM: 87.5-108 MHz & 870 - 960 MHz @ SWR \leq 1.6 (GSM 900) & 1.71-1.88 GHz @ SWR \leq 1.8 (GSM 1800)
Impedance	AM-FM band: 150 Ω ; GSM bands 900/1800: 50 Ω
Radiation (H-plane)	360° omnidirectional
Polarization	Linear Vertical
Antenna Gain	0 dB ref. to $\lambda/4$ whip
Decoupling Phone plug to Radio plug	\geq 30 dB
Max Power (CW) @ 30° C	20 Watts for GSM bands
Cable Type / Length / Connector	AM-FM: RG316/165mm,6.5in/M10x0.75-male GSM: RG316 / 120mm, 4.7in / FME-male
Mechanical Data	
Materials	Nylon, Chromed Brass, Copper, Aluminium
Height (approx.)	450 mm, 1.5 ft
Weight (approx.)	120 gr, 0.26 lb
Mounting Hole	\varnothing 18 mm, 0.7 in or square 15 mm, 0.6 in
Mounting Depth	12 mm, 0.5 in
P/N	2216115.00

SKA, SKA MAG series MICROMAG 918

Features:

- # MICROMAG 918: Magnetic antenna, Omnidirectional, Multi-band
- SKA, SKA MAG series: Hole or Magnetic, Omnidirectional, Mono-band
- # Ultra strenght neodinium magnet, No tuning required
- # MICROMAG 918: for AMPS, ISM, GSM 900/1800 systems
- # SKA, SKA MAG series: for AMPS, ISM, GSM 900 or GSM 900 systems

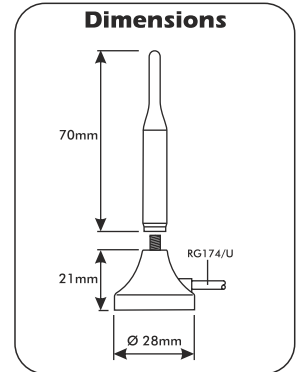
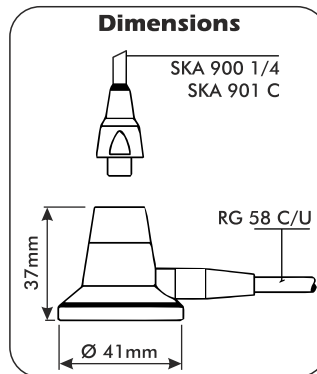
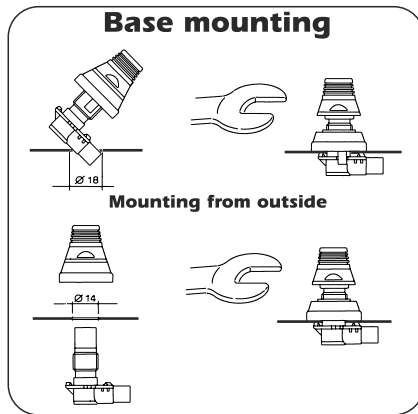

SKA 900 1/4

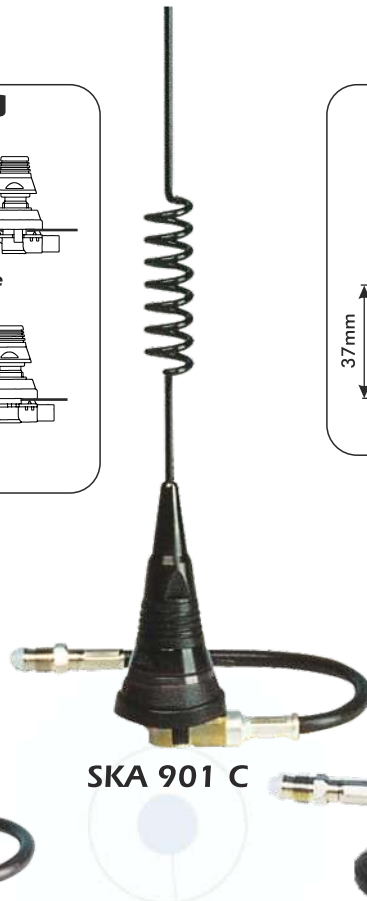

SKA 901 C



SKA 901 C MAG

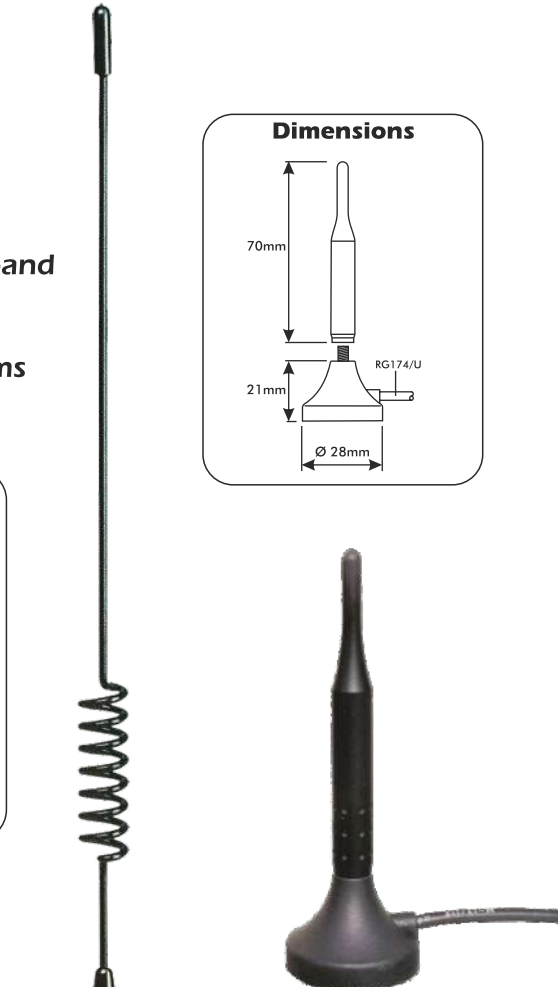

MICROMAG 918 1/4

Electrical Data	SKA 900 1/4	SKA 901 C	SKA 900 1/4 MAG	SKA 901 C MAG	MICROMAG 918 1/4
Type	1/4 λ	1/4 λ + 5/8 λ. Colinear	1/4 λ	1/4 λ + 5/8 λ. Colinear	1/4 λ both band
Frequency Range	824 - 960 MHz @ SWR ≤ 1.8 (AMPS, ISM, GSM 900)	880 - 960 MHz @ SWR ≤ 2.2 (GSM 900)	824 - 960 MHz @ SWR ≤ 1.8 (AMPS, ISM, GSM 900)	880 - 960 MHz @ SWR ≤ 2.2 (GSM 900)	824-960 & 1710-1880 MHz @ SWR ≤ 2.0 (AMPS, ISM, GSM 900 & 1800)
Impedance					50 Ω
Radiation (H-plane)					360° omnidirectional
Polarization					Linear Vertical
Gain	0 dB ref. to λ/4 whip	3.5 dB ref. to λ/4 whip	0 dB ref. to λ/4 whip	3 dB ref. to λ/4 whip	0 dB ref. to λ/4 whip
Max Power (CW) @ 30° C	30 Watts	30 Watts	30 Watts	30 Watts	20 Watts
Cable Type / Length	RG 58 C/U / 5 m, 16.4 ft	RG 58 C/U / 5 m, 16.4 ft	RG 58 C/U / 3 m, 10 ft	RG 58 C/U / 3 m, 10 ft	RG 174/U / 3 m, 10 ft
Connector					FME-female, other on request
Mechanical Data					
Materials	Stainless Steel 17/7 PH, Chromed Brass, Nylon	Chromed Brass, Black Chromed Stainless Steel	Stainless Steel 17/7 PH, Chromed Brass, Nylon	Chromed Brass, Black Chromed Stainless Steel	Nylon, Chromed Brass, Stainless Steel
Height (approx.)	90 mm, 3.5 in	320 mm, 12.6 in	68 mm, 2.7 in	295 mm, 11.6 in	90 mm, 3.5 in
Weight (approx.)	260 gr, 0.57 lb	280 gr, 0.6 lb	250 gr, 0.55 lb	280 gr, 0.6 lb	80 gr, 0.2 lb
Mounting	"ML" mount / hole Ø 14, 0.55in or 18 mm, 0.7 in Magnetic, with ultra strength Neodinium magnet				
P/N	2207130.26	2208906.26	2207130.75	2208906.75	2217106/3FME

INGLASS series

Features:

- # In-doors antennas, Omnidirectional, Multi-band, Unity gain
- # No tuning required
- # Adhesive on not metallic surface mount, flat profile
- # INGLASS MULTIBAND: for ISM, GSM 900/1800, UMTS systems
- INGLASS LTE & WLAN: for LTE, GSM dual, UMTS, WLAN 2.4 & 5GHz (IEEE 802.11b/g/h/p) V2X system



Adhesive installation Multi-band

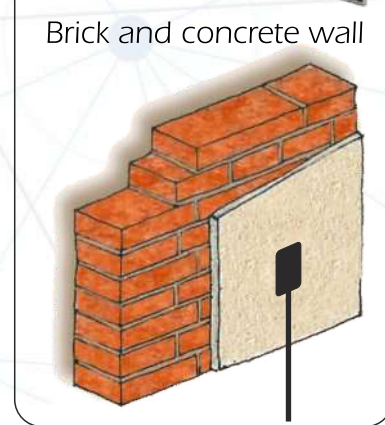
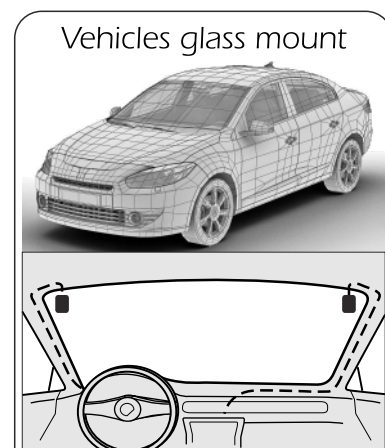
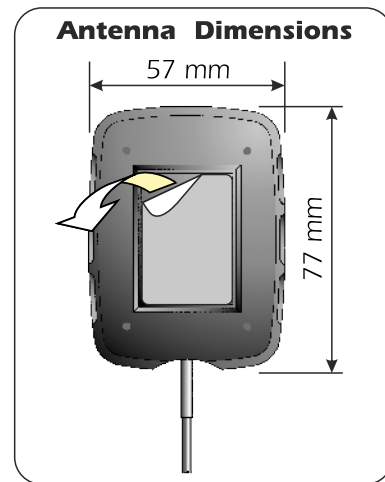

Electrical Data	INGLASS MULTIBAND	IN-GLASS LTE & WLAN
Type	1/2 λ dipole	
Frequency Range	868 - 960 MHz @ SWR ≤ 2.0 & 1.71 - 2.17 GHz @ SWR ≤ 2.0 (ISM 868, ISM 915, GSM dual, UMTS)	800 - 810 MHz @ SWR ≤ 2.6 & 810 - 960 MHz @ SWR ≤ 2.0 & 1.71 - 5.925 GHz @ SWR ≤ 2.2 (LTE, GSM dual, UMTS, WiMAX, WiFi IEEE 802.11b/g/h/p, V2X system)
Impedance	50 Ω	
Radiation (H-plane)	360° omnidirectional	
Polarization	Linear Vertical	
Gain	0 dBd, 2.15 dBi all bands	
Max Power (CW) @ 30° C	10 Watts	10 Watts from 800 to 2700 MHz 6 Watts from 2.7 to 3.8 GHz 5 Watt from 3.8 to 5.925 GHz
Cable Type / Length	RG 174 / 3 m, 10 ft	
Connector	FME-female or SMA-male	SMA-male
Mechanical Data		
Materials	PCB, Thermoplastic	
Dimensions (approx.)	57 x 77 x 10 mm, 2.2 x 3 x 0.4 in	
Weight (approx.)	70 gr, 0.15 lb	
Mounting	Adhesive tape, suitable for «not metallic» surfaces	
P/N SMA-m connector	2215902/3SMA	2216802/3SMA
P/N FME-f connector	2215902/3FME	/



Base "ML" w/cable/FME-f

Frequency range: from DC to 1000 MHz
 Overall Size: \varnothing 30 mm, 1.2 in
 Mounting Hole: \varnothing 14mm, 0.55in or 18mm, 0.7 in
 Material: Chromed Brass, Nylon, Siliconic Rubber
 Cable Type / Length / Connector: RG 58 C/U / 5m, 16.4 ft / FME-female
 ML mount w/cable 2509305.00

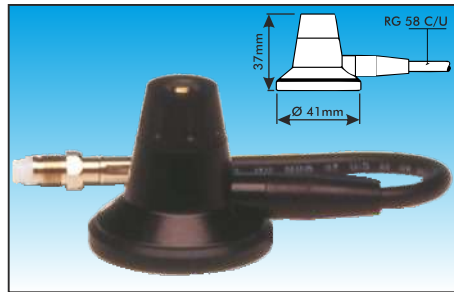

"CELL MAG" Magnetic Mount

Frequency range: from DC to 1000 MHz
 Overall Size: \varnothing 41 mm, 1.6 in
 Mounting: Magnetic with ultra strenght neodinium magnet
 Material: Chromed Brass, Nylon, Siliconic Rubber
 Cable Type / Length / Connector: RG 58 C/U / 3m, 10ft / FME-female
 CELLMAG magnetic mount 2510202.06

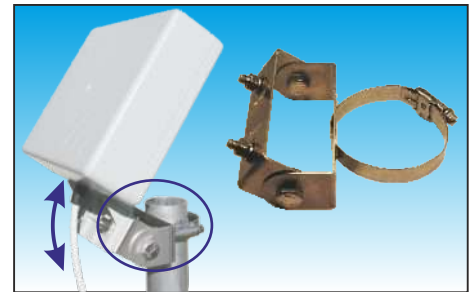

Tilting Bracket for SMP series

Material: Stainless Steel.
 Installation: mast \varnothing 35-50 mm, 1.4-2 in with damp included
 wall with mounting screws (not included)
 Tilting Bracket for SMP series 2519703.00

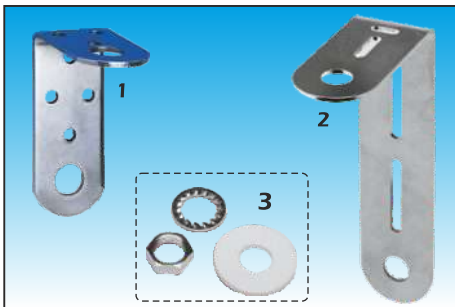

"M-1", "M-2" Marine Brackets

Dimension: M1: 38 x 64 x 98 mm, 1.5 x 2.5 x 3.8 in;
 M2: 45 x 100 x 180 mm, 1.5 x 3.9 x 7 in
 Material: Stainless Steel. Mounting Hole: 2 x \varnothing 16 mm, 0.63 in
 1 M-1 Marine Bracket 2503503.00
 2 M-2 Marine Bracket 2503203.00
 3 With Optional fixing set 2503203.00/SA or 2503503.00/SA

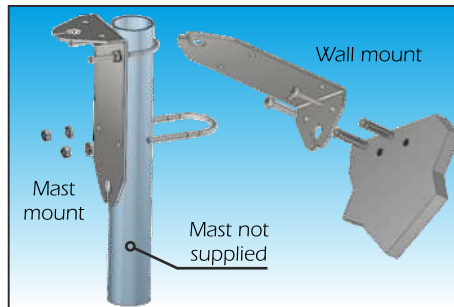

"M-3" Fixing Bracket

Dimension: 60 x 70 x 195 mm, 2.4 x 2.75 x 7.7 in
 Material: Zinc Plated Steel. Antenna fitting: 2 x \varnothing 16 mm, 0.63 in
 Mounting on Mast: \varnothing 35-42 mm, \varnothing 1.4-1.65 inch with U-bolt
 Mounting on Wall: with screws (not included)
 M-3 Bracket 2503604.00

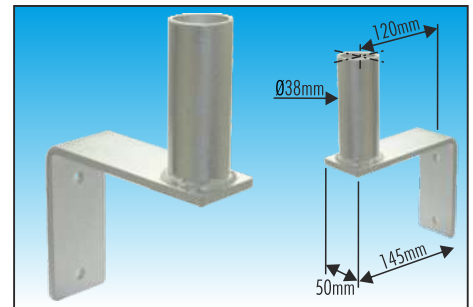

"FT-4" Fixing Bracket

Top Size for antenna fitting: \varnothing 38 x 100 mm, \varnothing 1.5 x 3.9 in
 Dimension L x W x H (approx.): 50 x 145 x 220 mm, 2 x 5.7 x 8.7 in
 Bottom Size: 2 x \varnothing 9 mm, 0.35 in wall fitting (screws not included).
 Weight (approx.): 780gr, 1.7 lb.
 Material: Galvanized Steel.
 FT-4 2513404.00



Extension cable w/2 FME-f

Cable Type / Connectors: RG 58 / 2 x FME-female
 0.5 m, 1.6 ft RG 58 Cable 2 x FME-f 2510305.00
 1.5 m, 4.9 ft RG 58 Cable 2 x FME-f 2510405.00
 3.5 m, 11.5 ft RG 58 Cable 2 x FME-f 2510505.00
 4.0 m, 13.1 ft RG 58 Cable 2 x FME-f 2510705.00
 5.0 m, 16.4 ft RG 58 Cable 2 x FME-f 2510605.00

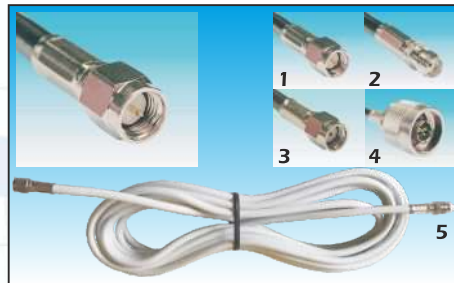

Extension cable w SMA-male /

Cable Length / Type: 5m, 16.4 ft / Low Loss
 1 SMA-male / SMA-male 2550906/5C0
 2 SMA-male / SMA-female 2550106/5C0
 3 SMA-male / SMA-male Reverse Polarity 2550506/5C0
 4 SMA-male / N-male 2550706/5C0
 5 SMA-male / FME-female 2550206/5C0

Other lengths or connectors: on request, minimum quantity order 100pcs.

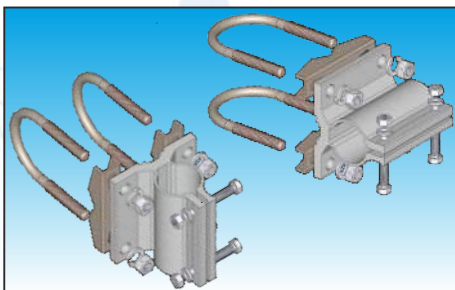

Fixing bracket for "WY" & "SPO" series

Material: Extruded Aluminium, Hardware: Stainless Steel.
 Installation: mast \varnothing 35-52 mm, 1.4-2.0 in with clamp included
 Dimensions: 80x76x65mm, 3.1x3x2.3 in. Weight 460 gr, 1 lb
 WY-SPO brackest SA197

"Antennas' Dispenser"

Overall Dimension W x H: 86 x 230 cm, 2.8 x 7.5 ft
 Material: Painted steel.
 Max weight capacity: 20 Kg, 44 lb
 Antenna's dispenser 32.0002

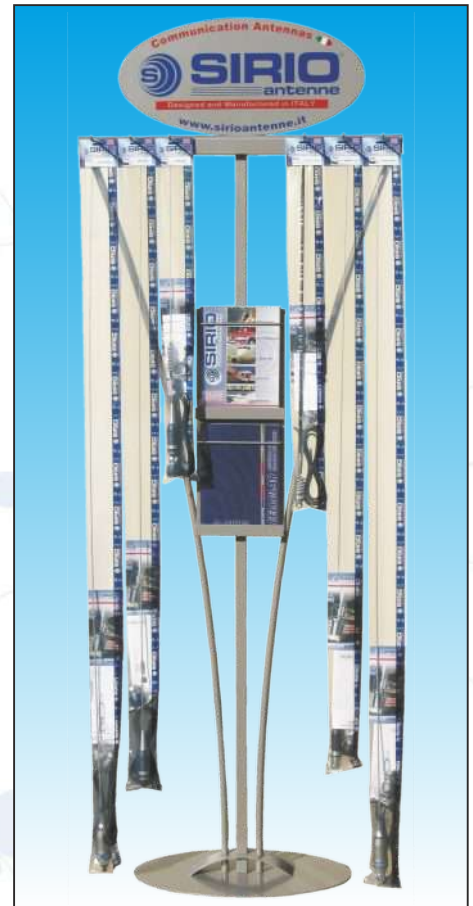



SMA-male

Frequency: from DC to 9 GHz. Materials: Nickel plated brass, PTFE insulator, Gold plated pin.
Crimp type for RG 58, CO 100 30.SMA001.00
Crimp type for RG 174, RG 316 30.SMA002.00



SMA-female

Frequency: from DC to 9 GHz. Materials: Nickel plated brass, PTFE insulator, Gold plated pin.
Crimp type for RG 58, CO 100 30.SMA003.00
Crimp type for RG 174, RG 316 30.SMA004.00



SMA-male Reverse Polarity

Frequency: from DC to 9 GHz. Materials: Nickel plated brass, PTFE insulator, Gold plated pin.
Crimp type for RG 58, CO 100 30.SMA005.00
Crimp type for RG 174, RG 316 30.SMA006.00



SMA-female Panel

Frequency: from DC to 9 GHz. Materials: Nickel plated brass, PTFE insulator, Gold plated pin.
Crimp type for RG 58, CO 100 30.SMA008.00
Crimp type for RG 174, RG 316 30.SMA007.00



FME-male

Materials: Nickel plated brass, PTFE insulator, Gold plated central pin.
Crimp type for RG 58, CO 100 30.FME001.00
Crimp type for RG 174, RG 316 30.FME005.00



FME-female

Materials: Nickel plated brass, Delrin insulator, Gold plated central pin.
Crimp type for RG 58, CO 100 30.FME002.00
Crimp type for RG 174, RG 316 30.FME003.00



N-male

Frequency: from DC to 6 GHz. Materials: Nickel plated brass, PTFE insulator, Gold plated pin.
Crimp type for RG 58, CO 100 30.N001.00



N-female

Frequency: from DC to 6 GHz. Materials: Nickel plated brass, PTFE insulator, Gold plated pin.
Crimp type for RG 58, CO 100 30.N002.00



BNC-male

Frequency: from DC to 4 GHz. Materials: Nickel plated brass, PTFE insulator, Gold plated pin.
Crimp type for RG 58, CO 100 30.BNC001.00



TNC-male

Frequency: from DC to 4 GHz. Materials: Nickel plated brass, PTFE insulator, Gold plated pin.
Crimp type for RG 58, CO 100 30.TNC001.00



TNC-male Reverse Polarity

Frequency: from DC to 4 GHz. Materials: Nickel plated brass, PTFE insulator, Gold plated pin.
Crimp type for RG 58, CO 100 30.TNC002.00



FME-m / UHF-m adaptor

Materials: Nickel plated brass, Delrin insulator, Gold plated central pin.
P/N 30.AD002.00



FME-m / TNC-m adaptor

Materials: Nickel plated brass, Delrin insulator, Gold plated central pin.
P/N 30.AD003.00



FME-m / Mini UHF-m adaptor

Materials: Nickel plated brass, Delrin insulator, Gold plated central pin.
P/N 30.AD004.00



FME-m / BNC-m adaptor

Materials: Nickel plated brass, Delrin insulator, Gold plated central pin.
P/N 30.AD005.00



FME-m / N-m adaptor

Materials: Nickel plated brass, Delrin insulator, Gold plated central pin.
P/N 30.AD006.00

COAXIAL CABLES Data

Type	Impedance	External diameter	Colour
RG 58 C/U	50 Ω	4.95 mm	Black
Low Loss	50 Ω	4.95 mm	White
RG 174	50 Ω	2.8 mm	Black
RG316/U	50 Ω	2.5 mm	Brown

Attenuation dB for 100 m

Freq. Cable	25 MHz	50 MHz	100 MHz	200 MHz	300 MHz	400 MHz	500 MHz	800 MHz	1 GHz	1.6 GHz	1.8 GHz	2.0 GHz	2.2 GHz	2.4 GHz	2.5 GHz	3.0 GHz
RG 58 C/U	7	10	15	21	26	30	34	44	50	66	70	76	78	86	87	98
Low Loss	5	7	10	14	17	20	23	29	33	42	45	48	50	53	54	60
RG 174	13	18	27	39	48	56	64	84	95	124	133	141	150	159	162	184
RG316/U	12	17	26	38	47	55	62	80	91	118	126	134	141	149	152	169

While the information has been carefully compiled to the best of our knowledge, nothing is intended as representation or warranty on our part and no statement herein shall be construed as recommendation to infringe existing patents. SIRIO ANTENNE reserves the right to change on any time and without prior warning the technical specification on any product in this catalogue. Copyright ©2018



Via Liguria, 15
46049 Volta Mantovana (MN) - ITALY

Tel: +39.0376.801515
Fax: +39.0376.801254

www.sirioantenne.it / info@sirioantenne.it