

500 Watt DBS-Band Antenna Mount Amplifiers with Block Upconverter



FEATURES

- *Rugged 70 lb. antenna mount package*
- *Extended frequency available*
- *Complete RS-232/422/485 interface*
- *L-band input*

The **XTD-500DBS-B1** are compact self-contained, antenna mountable power amplifiers. Its design eliminates the need for an amplifier shelter as well as a long waveguide run between the amplifier and the antenna feed horn. RF harmonic filters, cooling, and monitoring & control systems are all self-contained within the HPA. These features provide high reliability, low maintenance costs, and low replacement costs.

The **XTD-500DBS-B1** incorporates power factor correction which minimizes line current distortion and reduces the required Volt-Amps. The combination of power factor correction and high efficiency TWTs reduces input Volt-Amps by 45% when compared to equivalent amplifiers. A high frequency resonant conversion power supply that is used accepts a wide range of prime power (180 to 260 VAC). The automatic features of the power supply include quick recovery from prime power outages and multiple helix fault resets (three fault cycles). A complete serial monitoring and control system is built into the unit.

The **XTD-500DBS-P1** may be configured for single thread, redundant or phase-combined operation. An optional linearizer is available to allow increased transmit power while meeting spectral regrowth requirements. A remote external controller is available to operate the HPA from user selected location. Mounting brackets can be supplied to mount the HPA to most popular antennas.



PERFORMANCE SPECIFICATION

Parameters	XTD-500DBS-B1	XTD-500DBS1-B1
FREQUENCY RANGE (extended frequency coverage available)		
Output	17.3 to 18.1 GHz	17.3 to 18.4 GHz
Input	950 to 1750 MHz	950 to 2050 MHz
LO Frequency	16350 MHz	
Input Level w/o Damage (maximum)	10 dBm	
Reference Signal	external 10 MHz reference	
OUTPUT POWER		
Traveling Wave Tube	500 W	
Rated Power @ Amplifier Flange	415 W	
GAIN		
Large Signal (minimum)	65 dB	
Small Signal (minimum)	70 dB	
Attenuator Range (continuous)	25 dB	
Maximum SSG Variation Over		
Any Narrow Band	1.3 dB per 80 MHz	
Per 500 MHz	4.0 dB	
Slope (maximum)	± 0.04 dB/MHz	
Stability, 24 hr. (maximum)	± 0.25 dB	
Stability, Temperature (maximum)	± 1.0 dB maximum over temperature range at any frequency	
INTERMODULATION (maximum) with two equal carriers	-18 dBc @ 4 dB total output power backoff from rated power	
HARMONIC OUTPUT (maximum)	-60 dBc	
AM/PM CONVERSION (maximum)	3.0 deg/dB at 6 dB below rated output power	
NOISE POWER (maximum)		
Transmit Band	-70 dBW/4 kHz	
Receive Band	-150 dBW/4 kHz 10.95 to 12.75 GHz	
GROUP DELAY (maximum)		
Bandwidth	Any 80 MHz	
Linear	0.01 nS/MHz	
Parabolic	0.005 nS/MHz ²	
Ripple	0.5 nS/Pk-Pk	
RESIDUAL AM NOISE (maximum)	-50 dBc to 10 kHz -20 (1.5 + logf) dBc 10 to 500 kHz -85 dBc above 500 kHz	
PHASE NOISE (maximum)	Per IESS phase noise profile AC fundamental -50 dBc Sum of all spurs -47 dBc	
VSWR		
Input (maximum)	1.8:1	
Output (maximum)	1.3:1	

BLOCK DIAGRAM

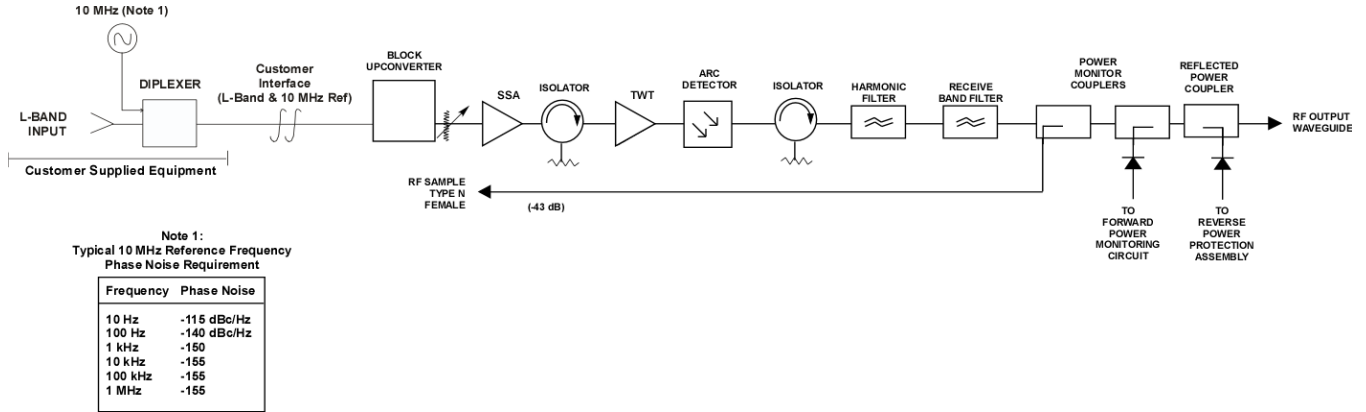

OUTLINE DRAWING

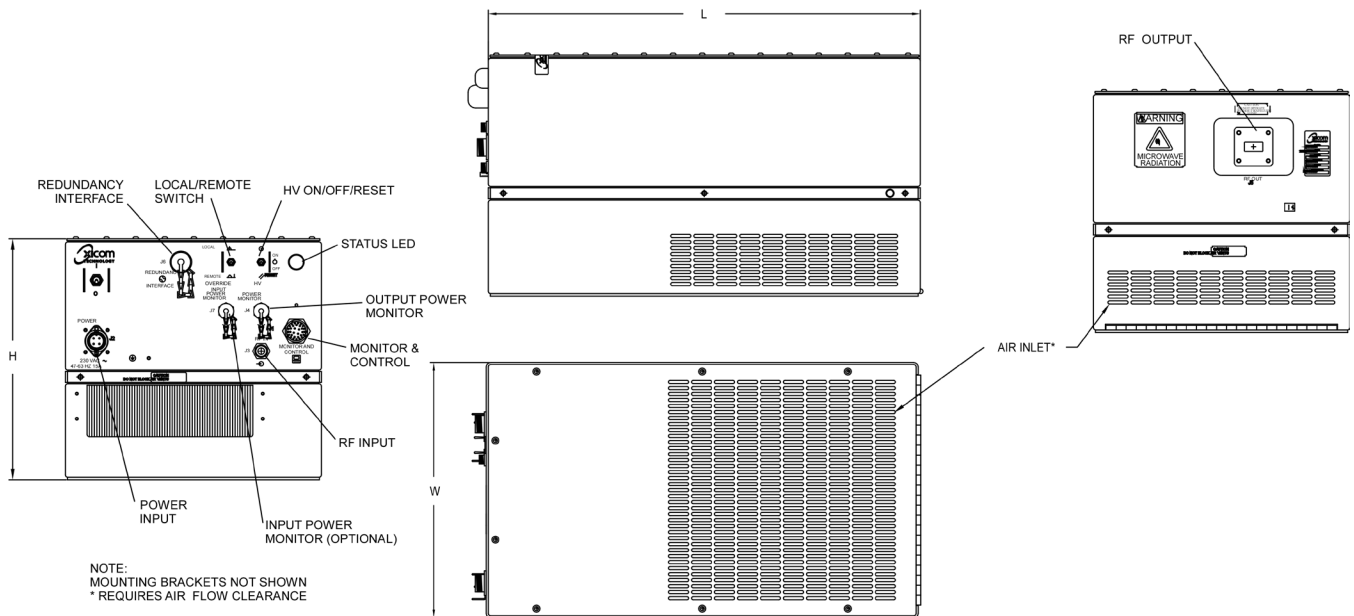

DIMENSIONS		
	INCHES	CENTIMETERS
L	21.50	54.61
H	12.13	30.81
W	12.75	32.39

RF OUTPUT = WR-62

Nominal Weight = 75 lbs (34.02 kg)

PRIME POWER

180 to 260 VAC
47 to 63 Hz, Single Phase
2300 VA (maximum)
0.95 Minimum Prime Power Factor



ENVIRONMENT

NONOPERATING TEMPERATURE RANGE	-50°C to +70°C
OPERATING TEMPERATURE RANGE	-40°C to +50°C
HUMIDITY	Up to 100% Condensing
ALTITUDE	10,000 Feet MSL (maximum)
SHOCK AND VIBRATION	Normal Transportation
COOLING	Forced Air

INTERFACE

Type	Function	
LOCAL CONTROL	Prime Power ON/OFF	Local/Remote
	Power Supply ON/OFF	HV ON/OFF
LOCAL STATUS	Tri-Color LED:	
	Fault: Red	Standby: Continuous Amber
	HV ON: Green	FTD: Flashing Amber
REMOTE CONTROL	HV ON/OFF	RF Inhibit (HV OFF)
	RF Attenuation (w/preamp)	Fault Reset
	Heater Standby	
REMOTE STATUS	HV ON	Heater/Beam Hours
	RF Output Power	Fault Identification
	Reflected Power	TWT Temperature
	Filament Time Delay	Helix Current
	Helix Voltage	
FORM C DRY CONTACT CLOSURE	Summary Fault	
RF MONITOR PORT	-43 dB Coupling Value (approx.)	

OPTIONS

- Extended Frequency Coverage
- Linearizer
- Parallel (Discrete) Interface
- Remote External Controller
- 1:1, 1:2, 1:N Redundancy

Headquarters

Comtech Xicom Technology, Inc.
3550 Bassett Street
Santa Clara, CA 95054
USA

Phone: +1-408-213-3000

Fax: +1-408-213-3001

email: sales@xicomtech.com

Web: www.xicomtech.com

European Sales Office

Comtech Xicom Technology Europe, LTD
4 Portland Business Center
Manor House Lane
Datchet
Berkshire SL3 9EG
United Kingdom

Phone: +011 44 (0) 1753 549 999

Fax: +011 44 (0) 1753 549 997

email: sales@xicomeurope.com

Web: www.xicomtech.com

Singapore Sales Office

Comtech Xicom Technology
150 Cecil Street
#08-02
Singapore 069543

Phone: +011 65 6325 1953

Fax: +011 65 6325 1950

email: asiasales@xicomtech.com

Web: www.xicomtech.com