

2250 Watt X-Band Rack Mount Amplifier with Touchscreen



FEATURES

- *Touch screen interface*
- *Built-in redundancy controller*
- *Ethernet interface, remote diagnostics*
- *Parameter trend analysis*
- *Optional integrated linearizer*

XTRT-2000X digital rack mount amplifiers are designed for fixed and mobile uplink applications and occupy only 11 rack units while providing 2 KW RF output power. These high efficiency traveling wave tube amplifiers include RF gain control, a solid state pre-amplifier, RF filters, cooling, and monitor & control (M&C) systems. An integrated X-Band linearizer option is available. The dual drawer amplifier conserves rack space and occupies only 19.25 inches (11 rack units) of a standard 19 inch rack cabinet. A complete 1:1 or 1:2 redundant TWTA system, including a redundant controller, can be mounted in a single rack.

The unit features a menu driven front panel display and RS-232 & RS-422/RS-485 and Ethernet serial port interfaces for complete remote control. Gain Control is set by the front panel manual control or by computer commands sent via the remote interfaces.



PERFORMANCE SPECIFICATION

Parameters	XTRT-2000X
FREQUENCY RANGE (extended frequency coverage available)	7.90 to 8.40 GHz
OUTPUT POWER	
Traveling Wave Tube	2250 W
Rated Power @ Amplifier Flange (minimum)	2000 W
GAIN	
Large Signal (minimum)	75 dB
Small Signal (minimum)	78 dB
Attenuator Range (continuous)	25 dB
Maximum SSG Variation Over:	
Any Narrow Band	1.0 dB per 40 MHz
Full Band	2.5 dB
Slope (maximum)	± 0.04 dB/MHz
Stability, 24 hr. (maximum)	± 0.25 dB
Stability, Temperature (maximum)	± 1.0 dB over temperature range at any frequency
INTERMODULATION (maximum) with two equal carriers	-23 dBc @ 7 dB total output power backoff from rated power, -25 dBc @ 3 dB total output power backoff with linearizer
HARMONIC OUTPUT (maximum)	-60 dBc
AM/PM CONVERSION (maximum)	2.5 deg/dB at 6 dB below rated power
NOISE POWER (maximum)	
Transmit Band	-70 dBW/4 kHz
Receive Band	-70 dBW/4 kHz 7.25 to 7.75 GHz
GROUP DELAY (maximum)	
Bandwidth	Any 40 MHz
Linear	± 0.01 nS/MHz
Parabolic	± 0.005 nS/MH ²
Ripple	0.5 nS/Pk-Pk
RESIDUAL AM NOISE (maximum)	-50 dBc to 10 kHz -20 (1.5 + logf) dBc 10 to 500 kHz -85 dBc above 500 kHz
PHASE NOISE (maximum)	10 dB below IESS phase noise profile AC fundamental -50 dBc Sum of all spurs -47 dBc
VSWR	
Input (maximum)	1.25:1
Output (maximum)	1.3:1

BLOCK DIAGRAM

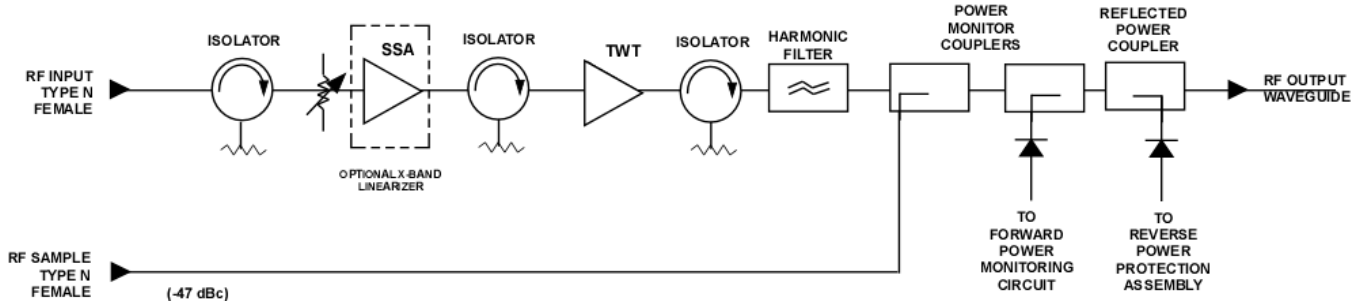

OUTLINE DRAWING

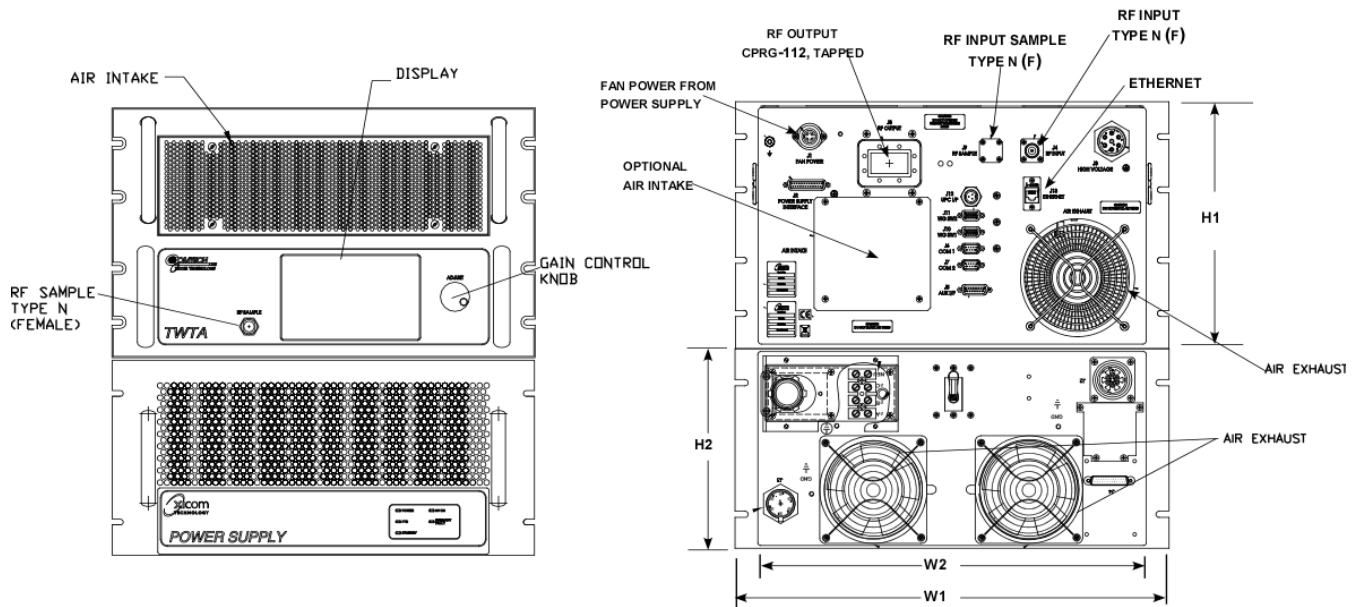

**RF OUTPUT
(WAVEGUIDE FLANGE)**
CPRG-112, Tapped

DIMENSIONS		
	Inches	Centimeters
H1	10.09	25.62
H2	8.72	22.15
L	24.125	61.27
W1	19.00	48.27
W2	17.00	43.18
Nominal Weight = 180 lbs (81.65 kg)		

PRIME POWER

208 VAC ± 10% Three Phase, 4 Wire, 47 to 63 Hz
7500 VA (typical)
0.95 Minimum Prime Power Factor



ENVIRONMENT

NONOPERATING TEMPERATURE RANGE	-50°C to +70°C
OPERATING TEMPERATURE RANGE	-10°C to +50°C
HUMIDITY	Up to 95% Noncondensing
ALTITUDE	10,000 Feet MSL (maximum)
SHOCK AND VIBRATION	Normal Transportation
COOLING	Forced Air 275 CFM (typical)

INTERFACE

	Type	Function	
CONTROLS	LOCAL	Local/Remote	AC Power On/OFF
	LOCAL AND REMOTE	Gain	High Voltage ON/OFF
		Min/Max Power Alarm/Fault	Audio Alarm ON/OFF
		Reflected Power Alarm/Fault	Units (Watts, dBm, dBW)
		Fault Reset	Lamp Test
	Heater Standby ON/OFF	System	
STATUS	FRONT PANEL LCD	Standby	Power
		Local	Remote
		Summary Fault	High Voltage ON/OFF
		Heater Time Out (FTD)	Heater Standby
		Power Out	Beam Hours
		Reflected Power	Helix Current
		TWT Temperature	Helix Voltage
		Heater Hours	Faults:
		Uplink Power (option)	High VSWR
		Event Log	High Voltage
		Trend Log	Helix Current
		System Status	TWT Temperature
			DRY FORM-C RELAY CONTACTS (2)
COMPUTER SERIAL PORT	HARDWARE INTERFACE	Two Ports: RS-232 & RS-422/RS-485 Ethernet T10/100	
	XICOM COMMAND SET	ASCII Commands	
	RF SAMPLE PORT COUPLING	-37 dB Nominal	

OPTIONS

- 220/380 VAC ± 10% Three Phase, 5 Wire, 47 to 63 Hz
- 240/415 VAC ± 10% Three Phase, 5 Wire, 47 to 63 Hz
- 1:1, 1:2, 1:N Redundancy
- Variable Phase Combined
- Integrated Linearizers

Headquarters

Comtech Xicom Technology, Inc.
3550 Bassett Street
Santa Clara, CA 95054
USA

Phone: +1-408-213-3000

Fax: +1-408-213-3001

email: sales@xicomtech.com

Web: www.xicomtech.com

Europe Sales Office

Comtech Xicom Technology Europe, LTD
4 Portland Business Center
Manor House Lane
Datchet
Berkshire SL3 9EG
United Kingdom

Phone: +011 44 (0) 1753 549 999

Fax: +011 44 (0) 1753 549 997

email: sales@xicomeurope.com

Web: www.xicomtech.com

Asia Sales Office

Comtech Xicom Technology
150 Cecil Street
#08-02
Singapore 069543

Phone: +011 65 6325 1953

Fax: +011 65 6325 1950

email: asiasales@xicomtech.com

Web: www.xicomtech.com