

400 Watt C, X and Ku-Band Antenna Mount Amplifiers With Block Upconverter



FEATURES

- *L-band input*
- *Rugged 55 lb. antenna mount package*
- *Extended frequency band available*
- *RS-232/422/485 M&C interface*
- *1:1, 1:2, 1:N redundancy*

The **XTD-400-B1** is a series of compact self contained antenna mountable power amplifiers with a built-in block upconverter designed for low cost installation and long life.

The **XTD-400-B1** design eliminates the need for an amplifier shelter as well as a long waveguide run between the amplifier and the antenna feed horn. For example, an antenna mount 400 Watt Ku-Band amplifier with its shorter waveguide run will often deliver EIRP comparable to a 600 Watt rack mount HPA.

RF filters, cooling, and monitoring & control systems are all self contained within the HPA. These features provide high reliability, low maintenance costs, and low replacement costs.

The **XTD-400-B1** uses high efficiency dual-stage collector Traveling Wave Tubes (TWT). Some benefits of this type of TWT are: reduced prime power consumption, lower internal operating temperatures, and reliability enhancement. These benefits are obtained for both the linear and saturated modes of operation.

The unit incorporates an L-Band block Upconverter, thereby eliminating the need for a separate outdoor unit (ODU). The L-Band transmit signal and a 10 MHz reference signal are brought out to the unit on a single coax line.

The **XTD-400-B1** may be configured for single thread, redundant, phase-combined, to linearized operation. A remote external controller is available to operate the HPA from a user selected locations. Mounting brackets can be supplied to mount the HPA to most popular antennas.



PERFORMANCE SPECIFICATION

Parameters	XTD-400C-B1 C-Band	XTD-400X-B1 X-Band	XTD-400K1-B1 Ku-Band
FREQUENCY RANGE (extended frequency coverage available)			
Output	5.850 to 6.425 GHz	7.9 to 8.4 GHz	13.75 to 14.5 GHz
Input	950 to 1525 MHz	950 to 1450 MHz	950 to 1700 MHz
LO Frequency	4900 MHz	6950 MHz	12800 MHz
Input Level, w/o damage (maximum)		10 dBm	
Reference Signal Frequency		external 10 MHz	
10 MHz Power Level		2 dBm \pm 5 dB	
OUTPUT POWER			
Traveling Wave Tube		400 Watts	
Rated Power @ Amplifier Flange (minimum)		350 Watts	
GAIN			
Large Signal (minimum)		67 dB	
Small Signal (minimum)		72 dB	
Attenuator Range (continuous)		25 dB	
Maximum SSG Variation Over			
Any Narrow Band	1.0 dB per 40 MHz	1.0 dB per 80 MHz	1.0 dB per 80 MHz
Full Band		\pm 2 dB	
Slope (maximum)		\pm 0.04 dB/MHz	
Stability, 24 hr. (maximum)		\pm 0.25 dB	
Stability, Temperature (maximum)		\pm 1.0 dB over temperature range at any frequency	
INTERMODULATION (maximum) with two equal carriers		-18 dBc @ 4 dB total output power backoff from rated power	
HARMONIC OUTPUT (maximum)		-60 dBc	
AM/PM CONVERSION (maximum)		2.5 deg/dB at 6 dB below rated power	
NOISE POWER (maximum)			
Transmit Band		-70 dBW/4 kHz	
Receive Band	-150 dBW/4 kHz 3.7 to 4.2 GHz	-150 dBW/4 kHz 10.95 to 12.75 GHz	-150 dBW/4 kHz 10.95 to 12.75 GHz
GROUP DELAY (maximum)			
Bandwidth	Any 40 MHz	Any 80 MHz	Any 80 MHz
Linear		0.01 nS/MHz	
Parabolic		0.005 nS/MHz ²	
Ripple		0.5 nS/Pk-Pk	
RESIDUAL AM NOISE (maximum)		-60 dBc > 100 kHz from carrier AC fundamental -50 dBc Sum of all spurs -47 dBc	
PHASE NOISE (maximum)		Per IESS phase noise profile	
VSWR			
Input (maximum)		1.8:1	
Output (maximum)		1.3:1	

BLOCK DIAGRAM

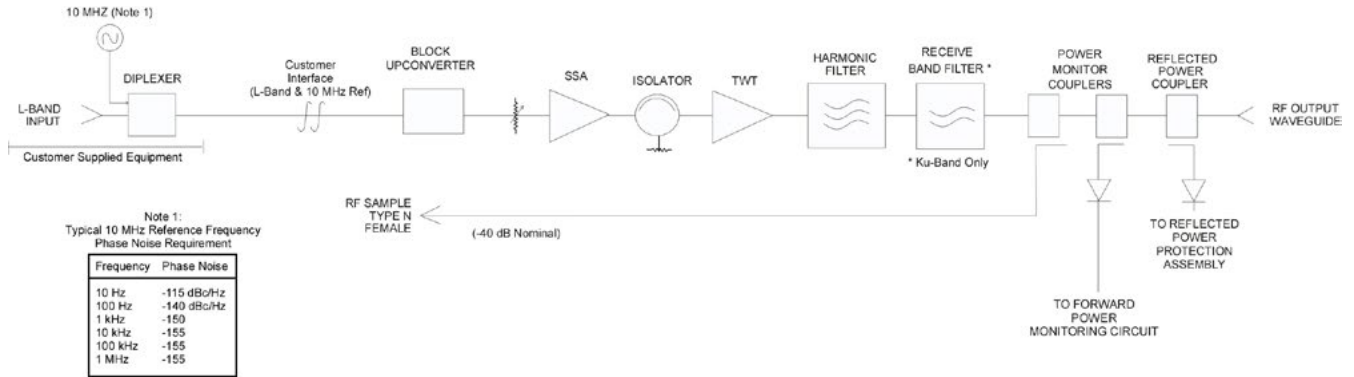

OUTLINE DRAWING

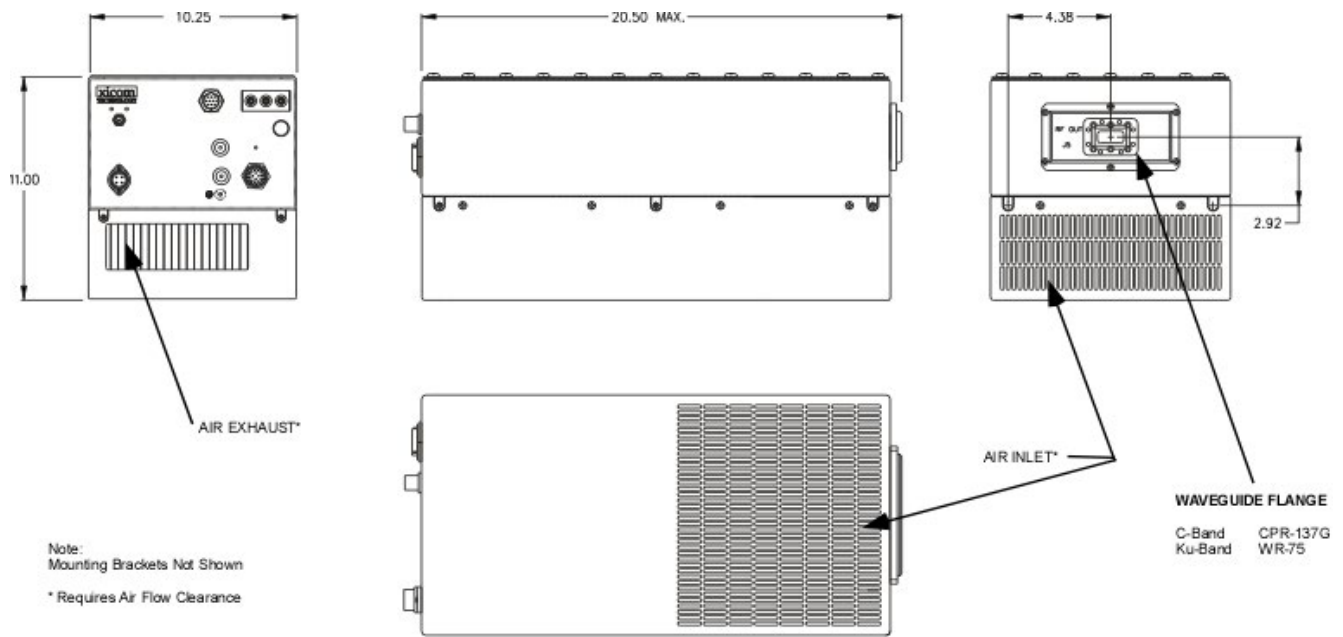

Note:
Mounting Brackets Not Shown
* Requires Air Flow Clearance

Typical Weight = 55 lbs (24.95 kg)

XTD-400-B1

PRIME POWER

100 to 260 VAC
 47 to 63 Hz, Single Phase
 1550 VA (maximum)
 0.95 Minimum Prime Power Factor



ENVIRONMENT

NONOPERATING TEMPERATURE RANGE	-50°C to +70°C
OPERATING TEMPERATURE RANGE	-40°C to +60°C (2°C/1000 Feet Derating)
HUMIDITY	Up to 100% Condensing
ALTITUDE	10,000 Feet MSL (maximum)
SHOCK AND VIBRATION	Normal Transportation
COOLING	Forced Air

INTERFACE

Type	Function	
LOCAL CONTROL	Prime Power ON/OFF Power Supply ON/OFF	Local/Remote HV ON/OFF
LOCAL STATUS	Tri-Color LED: Fault: Red HV ON: Green	Standby: Continuous Amber FTD: Flashing Amber
REMOTE CONTROL	HV ON/OFF Min/Max Power Alarm/Fault Reflected Power Alarm/Fault Heater Standby ON/OFF	Constant Power Gain Fault Reset Units (Watts, dBm, dBW)
REMOTE STATUS	Power Out Helix Current Heater Hours Attenuator Setting TWT Temperature	Reflected Power Helix Voltage Beam Hours Units Selection Faults: High VSWR High Voltage Helix Current TWT Temperature Arc Detection
FORM C DRY CONTACT CLOSURE	Summary Fault	
COMPUTER SERIAL PORT	Hardware Interface: RS-232 & RS-422/485	Xicom Command Set: ASCII Commands
RF MONITOR PORT	-40 dB Coupling Value (nominal)	

OPTIONS

- Remote External Controller
- 1:1, 1:2, 1:N Redundancy
- Integrated Linearizer
- Input Diplexer
(combining IF & 10 MHz reference)
- Reverse RF Input
- Ethernet Connector

Headquarters

Comtech Xicom Technology, Inc.
 3550 Bassett Street
 Santa Clara, CA 95054
 USA

Phone: +1-408-213-3000
 Fax: +1-408-213-3001

email: sales@xicomtech.com
 Web: www.xicomtech.com

European Sales Office

Comtech Xicom Technology Europe, LTD
 4 Portland Business Center
 Manor House Lane
 Datchet
 Berkshire SL3 9EG
 United Kingdom

Phone: +011 44 (0) 1753 549 999
 Fax: +011 44 (0) 1753 549 997

email: sales@xicomeurope.com
 Web: www.xicomtech.com

Asia Sales Office

Comtech Xicom Technology
 150 Cecil Street
 #08-02
 Singapore 069543

Phone: +011 65 6325 1953
 Fax: +011 65 6325 1950

email: asiasales@xicomtech.com
 Web: www.xicomtech.com

