

UHP-110

INTEGRATED SATELLITE ROUTER

TDM/TDMA

SCPC Rx-only

High-Throughput Satellites (HTS) open unprecedented opportunities for networking over satellite. UHP-110 is a high-performance integrated router designed specifically for large-scale deployment in broadband VSAT networks operating over HTS. This product combines the Universal Hardware Platform (UHP) architecture, which was developed in the previous generation of the award-winning UHP product line. Not only UHP-110 can process 200,000 IP packets per second, 200 Mbps of traffic and two 65 Msps carriers, it can do this in a super-compact size, with low power consumption (less than 10W) and with best utilization of the precious satellite resource, as evidenced by up to 32APSK modulation, 5% spectral roll-off, adaptive modulation and coding, adaptive power control and 96% efficient TDMA protocol.

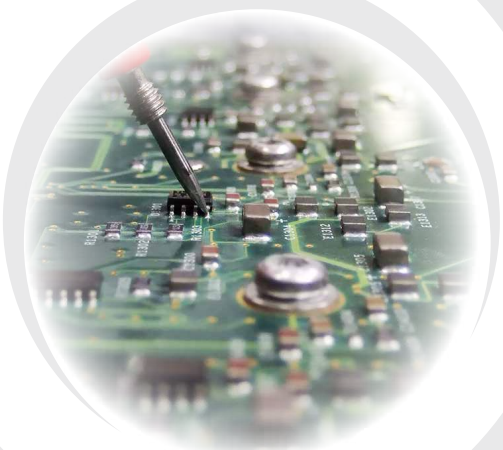

UHP-110 is equipped with two high-speed demodulators together with their independent IF inputs and front ends. These can simultaneously receive two carriers transmitted via two different satellite beams, which can even be in different frequency bands. The dual demodulator in conjunction with a built-in advanced beam switching algorithm facilitates seamless roaming of mobile satellite terminals between distinct beams of HTS satellites.

UHP-110 is implemented as a compact single card ideal for integration into third-party OEM products. The router card has LED indicators, SMA or F type IF connectors and user LAN interfaces. Optionally, the router card can be equipped with the asynchronous LVTTTL data port.

- High-performance Satellite Router for TDM/TDMA networks with aggregate throughput up to 200 Mbps
- Two independent DVB demodulators with separate IF inputs and rate up to 65 Msps
- Enhanced DVB-S2 QPSK, 8PSK, 16APSK and 32APSK modulations with 5% or 20% roll-off
- MF-TDMA modulator with innovative protocol and proven efficiency of 96% compared to SCPC
- Adaptive coding and modulation and transmission power control in forward and return channels
- Dual satellite or dual band operations with dynamic traffic balancing and automatic beam switching
- Superior IP router productivity up to 200'000 pps and reach set of supported protocols, including L2 bridging
- Support of Layer 3 routing architecture and Layer 2 bridging mode with IPV6 transport
- Support of VLAN, multilevel QoS, codec independent handling of RT traffic, TCP acceleration, AES encryption
- Built-in adaptive hierarchic traffic shaper specially designed for VSAT applications
- Two Ethernet user's ports with built-in switch simplifies connection of CPE and maintenance
- Ultra-low latency VSAT system with round-trip delay about 570 ms for TDMA mode of operations
- Low power consumption – less than 10 Watt (without RF ODU)



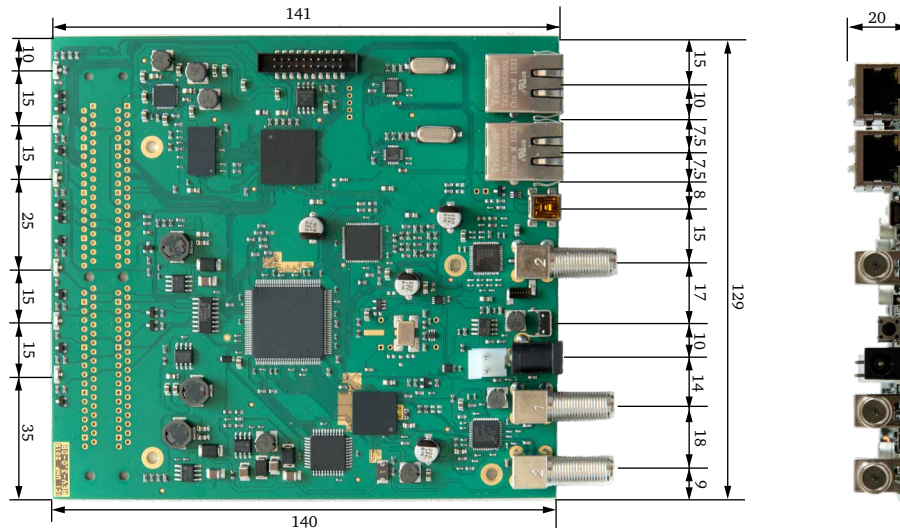

UHP-110 INTEGRATED SATELLITE ROUTER SPECIFICATIONS

NETWORK

Modes of operation	TDM/TDMA, Rx-only SCPC
Network role	TDM/TDMA terminal, SCPC receiver
Frequency bands	C, X, Ku, Ka, including multi-beam HTS satellites
Compatibility	UHP-200 or UHP-1000 based TDM/TDMA Hubs

TDM (SCPC) CHANNEL - Two demodulators with selectable IF inputs

Modulation	DVB S2 ACM: QPSK, 8PSK, 16APSK, 32APSK; TLC; roll-off 5% or 20%									
Symbol rate	300 kbps - 65 Msps with 1 kbps step; max. 53.8 Msps for 32APSK									
Data rate	200 kbps - 225 Mbps (225 Mbps of aggregate rate for two demodulators)									
C/N threshold levels, dB BER < 10 ⁻⁷ 20% roll-off (+0.1 dB for 5% RO)	FEC	1/3	2/5	1/2	3/5	2/3	3/4	4/5	5/6	8/9
	QPSK	-0.9	-0.0	1.1	2.7	3.6	4.4	5.0	5.5	6.5
	8PSK	-	-	-	6.1	7.1	8.4	-	9.7	11.3
	16APSK	-	-	-	-	9.4	10.8	11.5	12.2	13.4
	32APSK	-	-	-	-	-	14.6	15.8	16.9	18.4
QoS	3-level prioritization, traffic policies, CIR, MIR, group QoS, hierarchic traffic shaper, FAP									

TDMA CHANNEL (Tx-only)

Modulation	BPSK, QPSK, 8PSK; ACM; TLC; roll-off 5%* or 20%	
Symbol rate	100 kbps - 5 Msps (8 Msps*); 1 kbps step	
TDMA Protocol	Frame 50-1000 ms, 8 slot sizes, manageable minimal bandwidth; slot-to-slot fast MF-TDMA hopping	
C/N threshold levels, dB BER < 10 ⁻⁷ 20% roll-off	FEC	2/3 5/6
	QPSK	5.4 6.9
	8PSK	9.6 12.0
QoS	CIR, MIR, group QoS, FAP, RT traffic support, day/night, hierarchic manager of TDMA bandwidth	

ROUTER

Performance	Up to 200'000 packets per second
Support	DSCP, multiple IP/VLANs, NAT, proxy ARP, L2 Bridging, TCP Acceleration, AES-256 encryption
Protocols	DHCP, IGMP, SNMP, RIP, SNTP, TFTP, cRTP
Management	HTTP interface, SNMP, Telnet, NMS with VNO support

INTERFACES

User LAN	2 x Fast Ethernet, RJ-45
Maintenance console	MiniUSB, B female
IF Rx	950-2150 MHz (LO 10 MHz / +5 dBm, LNB DC - 13.5V/18V 0.75 A), F type
IF Tx	950-1750 MHz (optionally up to 2150 MHz), -45... -5 dBm, (LO 10 MHz/+5 dBm, 24V/2A), F type

MECHANICAL / ENVIRONMENTAL (IDU)

Power	24 VDC, 10 W
Operating temperature	0°... +50° C, humidity up to 90%



* Available with future SW releases



Request A Quote